

NEXT GENERATION MULTI-CABLE TRANSIT SEALING SYSTEM



APPROVED FIRESTOP/WATERTIGHT





**MAXIMUM SIMPLICITY OF USE
OPTIMUM FLEXIBILITY
OUTSTANDING PERFORMANCE**

Websites: <http://www.beele.com>, www.rise-systems.com and www.yfestos.com

Copyright : BEELE Engineering BV/CSD International BV, Aalten, the Netherlands.
Proprietary rights on all drawings and technical data released in this brochure.
© 1997-2003

Edition : January 2003

Note : No part of this publication may be reproduced without explicit written approval of BEELE Engineering BV.

Research & Development : BEELE Engineering BV, Aalten, the Netherlands.

Note : The manufacturer reserves the right to make dimensional and design modifications without prior notification.

® : **ACTIFIRE, ACTIFOAM, BEEBLOCK, BEELE, BEESEAL, CONDUCTION, CRUSHER, CSD, CSD THE SIMPLE SEAL SYSTEM, DRIFIL, FIRUB/NOHAL, FITEFIRE, FIWA, LEAXEAL, LUMIREFLEC, RAPID TRANSIT SYSTEM, RISE, RISWAT and YFESTOS** are registered trade marks of BEELE Engineering BV.

BEELE ENGINEERING BV CSD INTERNATIONAL BV

BEELE Engineering and CSD International have been working in the field of water and gas tight and fireproof sealing of conduits for pipes and cables for more than 25 years. In the field of passive fire prevention, we have invested substantial amounts of money in the development of systems which are capable withstanding fires for extended periods of time. Passive fire prevention is a very complicated matter due to the fact that cable and pipe penetrations have to be designed to the actual circumstances at site and not for a laboratory test. In case of a catastrophe penetrations are subject not only to flame erosion and very high temperatures, but also

to mechanical loads due to collapsing cable ways and possibly a jet of fire-fighting water. This means that the performance in actual situations can differ dramatically from that in a regular fire test. In fact, the systems could only be applied as tested to guarantee the required fire safety.

And this means discussions and limitations!

We have ensured that our systems will function under all circumstances, and the classification societies have awarded us signed and stamped installation drawings of our sealing systems. Approved for steel and aluminium partitions. Guaranteed safety in your installation will be the result.

The R&D department of BEELE Engineering is constantly working in the field of rubber and systems techniques to optimize the existing systems and to develop new concepts for cable and pipe conduits on board of vessels and offshore installations. Although installation of the CSD sealing systems is in fact an easy matter, a full training programme can be given in-house by our engineers. Because the advantages and possibilities of passive fire prevention and evacuation signposting can most effectively be discovered in an environment that matches the practical situation as closely as possible, work is currently proceeding on the construction of a unique research and development centre. As far is known, this R&D centre is the only institute world-wide where visitors can experience for themselves all the aspects of fire prevention and evacuation signposting systems.

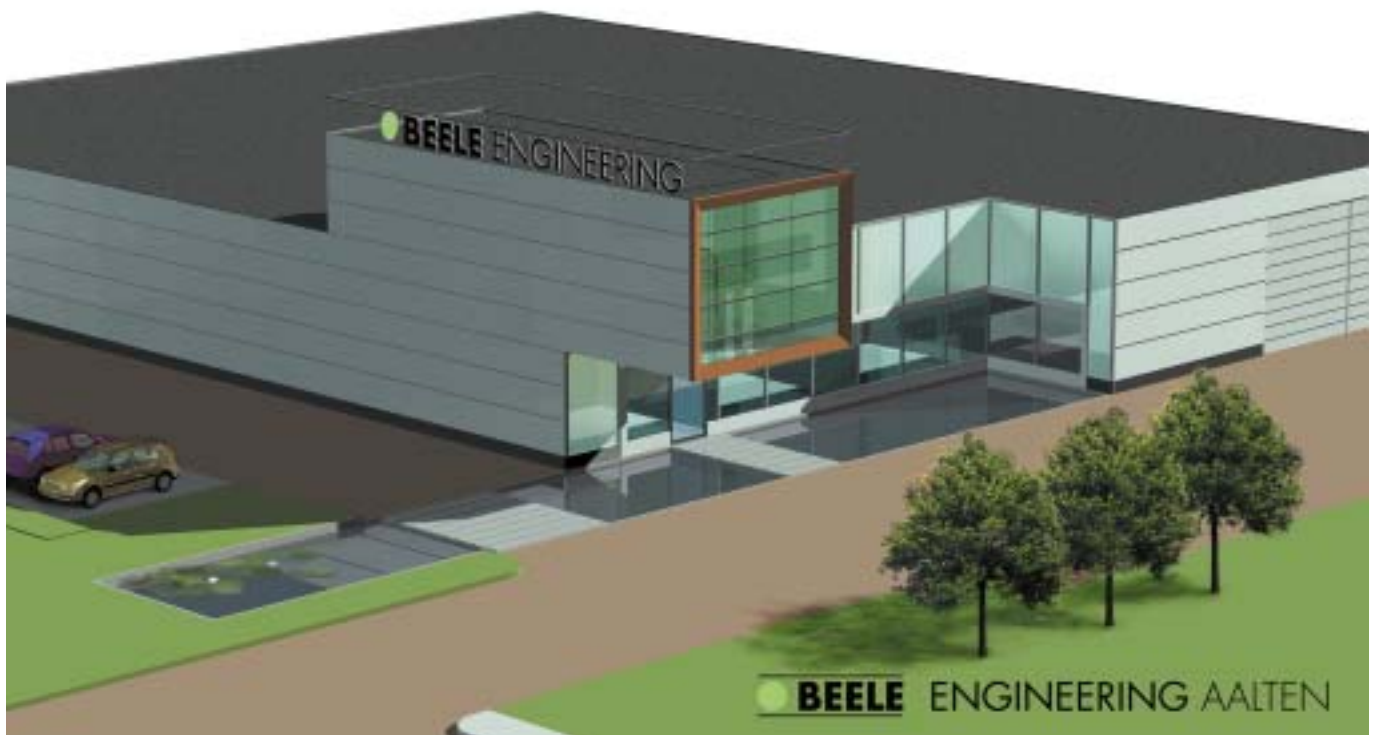

Research and development centre with a training and schooling institute for passive fire prevention products and systems and for the improvement of evacuation signposting systems in buildings and on board ships.

The centre consists of a presentation theatre seating up to 45 persons, and a mock-up covering about 500 square metres in which various evacuation signposting systems are installed to enable their effectiveness to be determined in the dark.

The behaviour of escaping persons inside the test facility can be recorded from a separate technical area (with an associated showroom) by means of infra-red cameras and an audio-video system.

In addition the centre comprises three laboratories with a total surface of about 300 square metres in which, respectively, large-scale fire tests, mechanical tests, and light emission investigations are performed.

RISE[®]

MULTI-CABLE PENETRATIONS

RISE[®] multi-cable penetrations are an alternative for the casting compounds and block systems used in fire-rated/watertight bulkheads and decks. Very easy to install.

Time saving, space saving, weight saving.

The very limited amount of different parts makes this system easy to handle on site. Use is made of rubber inserts (placed around the cables) and filler sleeves. The FRR/LEHF (fire resistant rubber/low grade of expansion, halogen free) rubber of the sleeves expands to 5 times its original volume when exposed to fire.

On both sides of the penetration a layer of FIWA[®] sealant (fire resistant, water repellent) is applied.

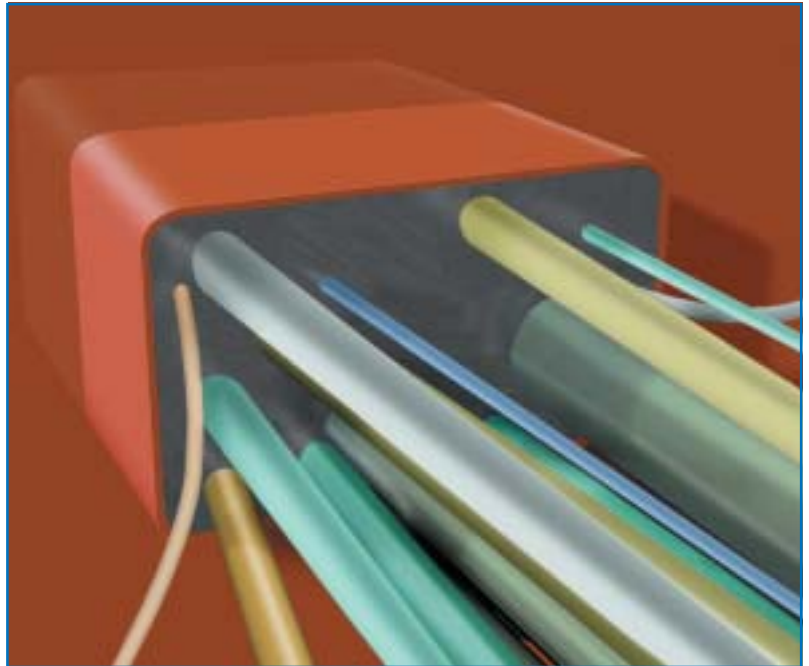

Only halogen free components used.

RISE[®] multi-cable transits offer the following outstanding properties:

**ALL COMPONENTS ARE TOTALLY HALOGEN FREE
IN CASE OF FIRE: NON-TOXIC, LOW SMOKE INDEX**

CE CERTIFICATES FOR A-0 UP TO A-60

CERTIFIED FOR H-0 UP TO H-120

APPROVED WATER TIGHT UP TO 2.5 BAR

APPROVED GAS TIGHT UP TO 1 BAR

HIGH LEVEL OF EMC AND SOUND DAMPING

SHOCK AND VIBRATION PROOF

UP TO 50 YEARS SERVICE LIFE

**CAPABLE OF ABSORBING TEMPERATURE
CHANGES**

RISE[®]

MULTI-CABLE PENETRATIONS

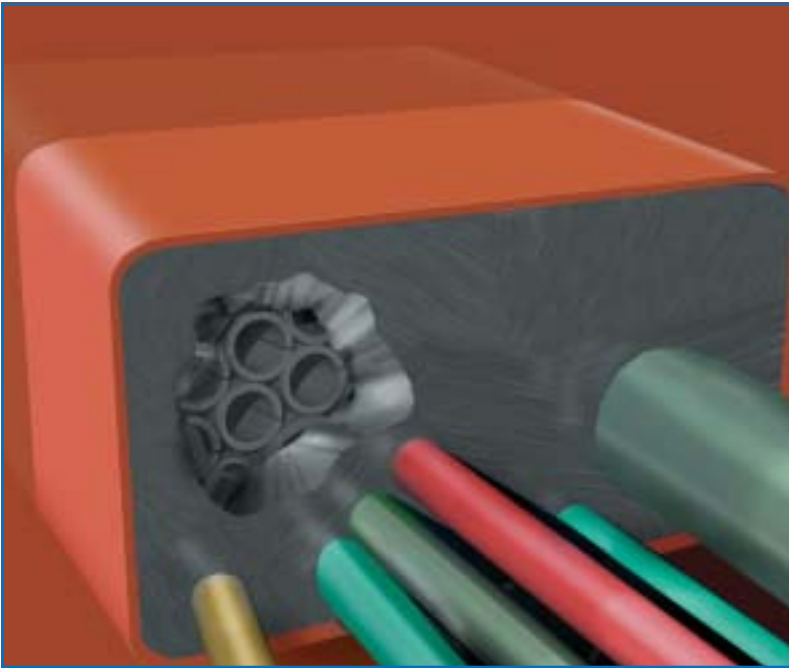

RISE[®] multi-cable penetrations offer a most simple way of installation. No precise positioning of the cables in the transit needed. The RISE[®] sealing system allows cables to be ducted through conduit openings in a bent, curved or oblique way without any adverse impact on sealing performance.

The RISE[®] sealing system gives easy access to add or remove cables in a later stage without the necessity to disassemble the whole penetration. Just cut away a piece of the FIWA[®] layer at both sides of the penetration, pull the cable through and refill the opening in the sealant layer. It is that simple!

RISE[®] multi-cable transits offer the following advantages:

NO PRE-ENGINEERING NEEDED

NO SPECIAL CONDUIT FRAMES

MINIMIZED NUMBER OF STRUCTURAL COMPONENTS

MOST COMPACT INSTALLATION

EXTREMELY SIMPLE TO INSTALL

NO INSULATION IN FRONT OF THE PENETRATION

SHORTEST POSSIBLE CONDUIT LENGTH

LESS OVERALL INSULATION NEEDED

CAN BE USED FOR CABLE AND PIPE ENTRIES

APPROVED FOR STEEL AND ALUMINIUM PARTITIONS

RISE[®]

MULTI-CABLE PENETRATIONS

**only two different components for a
RISE[®] cable penetration**

- 1) FRR/LEHF rubber insert sleeves
- 2) FIWA[®] sealant



| sleeve type | cable diameter | sleeve length (standard) | sleeve length (standard) | wall thickness |
|-------------|----------------|--------------------------|--------------------------|----------------|
| 12/6 | 5 - 7 | 160 | 210 | 3 |
| 14/8 | 7 - 9 | 160 | 210 | 3 |
| 16/10 | 9 - 11 | 160 | 210 | 3 |
| 18/12* | 11 - 13 | 160 | 210 | 3 |
| 20/14 | 13 - 15 | 160 | 210 | 3 |
| 22/16 | 15 - 17 | 160 | 210 | 3 |
| 27/19* | 17 - 21 | 160 | 210 | 4 |
| 31/23 | 21 - 25 | 160 | 210 | 4 |
| 35/27 | 25 - 29 | 160 | 210 | 4 |
| 39/31 | 29 - 33 | 160 | 210 | 4 |
| 46/36 | 33 - 39 | 160 | 210 | 5 |
| 52/42 | 39 - 45 | 160 | 210 | 5 |
| 58/48 | 45 - 51 | 160 | 210 | 5 |
| 64/54 | 51 - 57 | 160 | 210 | 5 |
| 70/60 | 57 - 63 | 160 | 210 | 5 |

* can be supplied non-split for ease of filling

dimensions in mm

For the RISE[®] insert sleeves, a special rubber compound was developed known as FRR/LEHF (fire resistant rubber/low grade of expansion, halogen free). When this rubber is exposed to fire or temperatures in excess of 200 °C (400 °F) it expands to five times its original volume. During the expansion of the rubber a carbonized mass is formed, which has good properties of thermal insulation.

The FRR/EHF rubber is absolutely HALOGEN FREE (tested according to Naval Engineering Standard NES 713: Issue 3).

Furthermore the FRR/LEHF rubber has a low smoke index (NES 711: Issue 2: 1981) and a very high oxygen index (ISO 4589-2: 1996).

The wall thickness of the sleeves is so chosen as to satisfy the requirements governing adequate separation of the cables.

Sometimes conduits are extremely oversized. For ease of filling of larger remaining spaces the filler sleeves 18/12 and 27/19 can be supplied as non-split multi-units of 10 pieces bonded together.

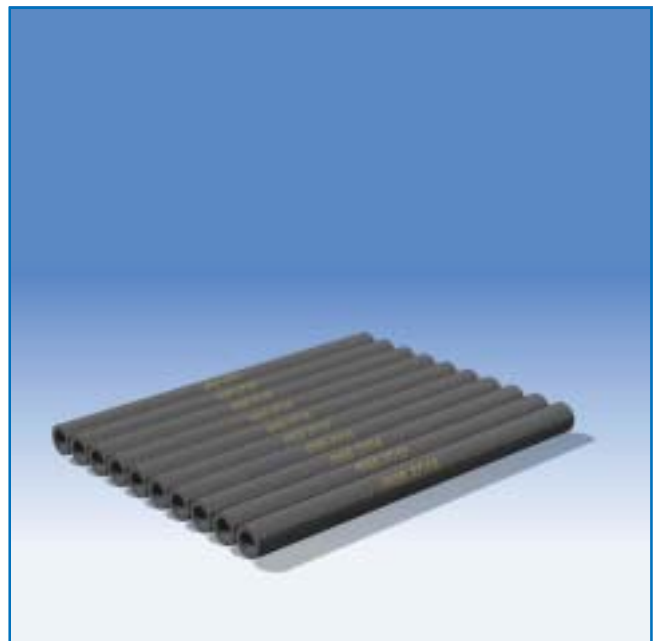

RISE[®]

MULTI-CABLE PENETRATIONS

**only two different components for a
RISE[®] cable penetration**

- 1) FRR/LEHF rubber insert sleeves
- 2) FIWA[®] sealant



FIWA[®] is a fire-resistant sealant based on a single component silicone compound.

FIWA[®] is also water-repellent

High bonding strength

UV and Ozone resistant

In the event of fire or at temperatures in excess of 200 °C (400 °F) the sealant expands to about 10 times its original volume. During this process a porous mass is formed, which has excellent thermal insulation properties. In contrast to conventional materials that swell under severe heat exposure, the expansion of FIWA[®] sealant is not caused by intumescence, but by a chemical process (Intumescence means the occurrence of volume enlargement under the effect of heat, caused by the surface structure being inflated by fumes originating from the product).

The advantage of this is that the expansion of FIWA[®] is not accompanied by formation of large amounts of fumes.

**optimum combination of viscosity, flow and
bonding capacity of FIWA[®] sealant**

PRODUCT INFORMATION

| | |
|-------------------------|--|
| 01) colour | dark grey |
| 02) specific gravity | 1.26 ± 0.03 g/cm ³ |
| 03) curing of top layer | 1 - 2 hours |
| 04) service temperature | -40 °C up to +160 °C |
| 05) tensile strength | 0.80 MPa |
| 06) elongation at break | 80% |
| 07) hardness | 40 Shore A |
| 08) elasticity | approx. 25% |
| 09) fire class | IMO Res. A.653(16) |
| 10) ageing | up to 50 years service life |
| 11) supplied in | cartridges, containing 310 ml |
| 12) storage | to be stored cool and dry min/max temperature = +5/+30° C |
| 13) storage life | approx. 6 months |



**FIWA is absolutely
HALOGEN FREE
(tested according to
Naval Engineering
Standard NES 713:
Issue 3).**

**Furthermore FIWA has
a low smoke index
(NES 711: Issue 2:
1981) and a high
oxygen index (ISO
4589-2: 1996),**

**and low flame spread
characteristics
according to IMO
Resolution A.653(16).**

RISE[®]

MULTI-CABLE PENETRATIONS

no pre-engineering needed for a RISE[®] multi-cable penetration

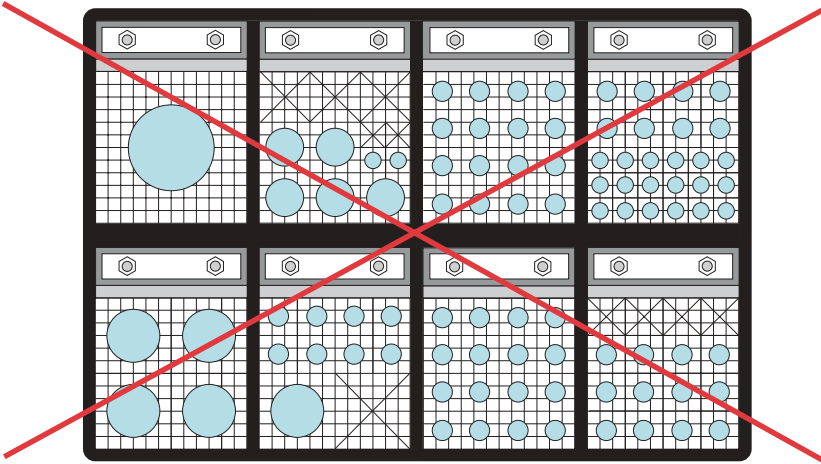

Since the cables can be ducted in random order through the conduit frame or sleeve it is not necessary to create layouts for the installers to be sure that the cables are ducted at the right spot in the conduit. We have a software program available for calculating the size of the conduit opening and the amount of insert sleeves and sealant for each RISE[®] penetration. All penetrations can be put in a database to calculate the total amount for a project (see page 38). Could it be easier?

no time-consuming lay-outs for a RISE[®] multi-cable penetration

no special conduit frames needed for a RISE[®] multi-cable penetration



An important benefit of being able to use round sleeves instead of square or rectangular ones is the exclusion of welding stresses in the corners and for the improved overall mechanical strength!

whatever conduit sleeve you have around will do for a RISE[®] multi-cable penetration

RISE[®]

MULTI-CABLE PENETRATIONS

***time-saving installation of
RISE[®] multi-cable penetrations***

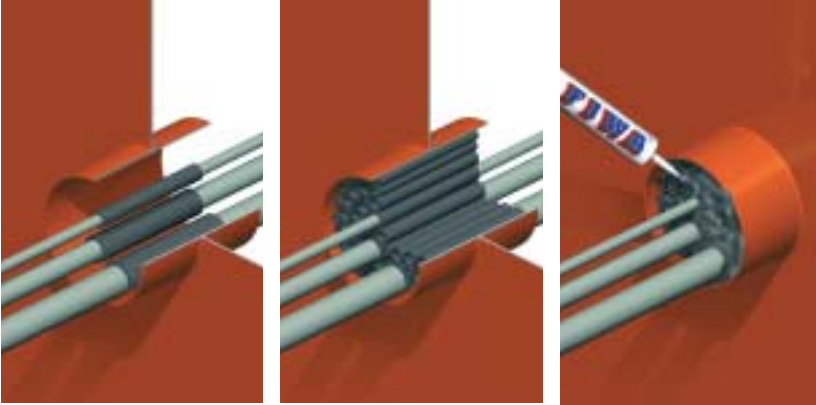

It's so simple. Just place the lengthwise split insert sleeves around the cables, fill up any spare space with empty sleeves and seal it off on both sides. No work for specialists. What could be easier! Calculate the right way, save time and money.



***no bolts, no nuts, no precise fitting work
with RISE[®] cable penetrations***

***space and weight saving properties of
RISE[®] multi-cable penetrations***

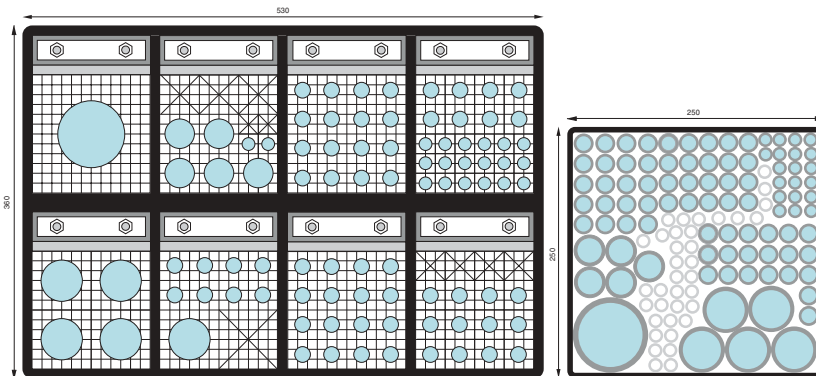

same amount of cables in less than half the conduit size with RISE[®]

Prefabricated sealing systems are sealed with solid rubber parts. Due to the block sizes a substantial separation of the cables might occur. Fire resistant rubbers are highly filled and therefore heavy. Totally different with RISE[®]. The conduit opening can be substantially reduced when compared to block systems, due to the high fill capacity of RISE[®], and any spare space in the conduit is filled with hollow insert sleeves. Scarcely any weight is added to the penetration even if the conduit is a bit oversized.

***smaller conduit openings
for RISE[®] cable penetrations***

RISE[®]

MULTI-CABLE PENETRATIONS

***fire tested on full scale bulkhead and deck
in accordance with IMO Res. A.754(18)***



Generally, multi-cable transits have to be installed as tested. It will be clear that a transit tested with only a couple of small cables will not meet an A60 classification when fully packed with heavy conductor cables. RISE[®] multi-cable penetrations are tested with all types of cables, from communication to power cables with small dimensions, up to cables with a dimension of 85 mm (3-1/2"), armoured and non-armoured, at full load and according to the latest IMO Resolution A.754(18).

***RISE[®] is successfully tested with a wide variety
of cable types and sizes up to 85 mm OD***

***RISE[®] is successfully tested with more than
100 cables to enable a high cable fill capacity***

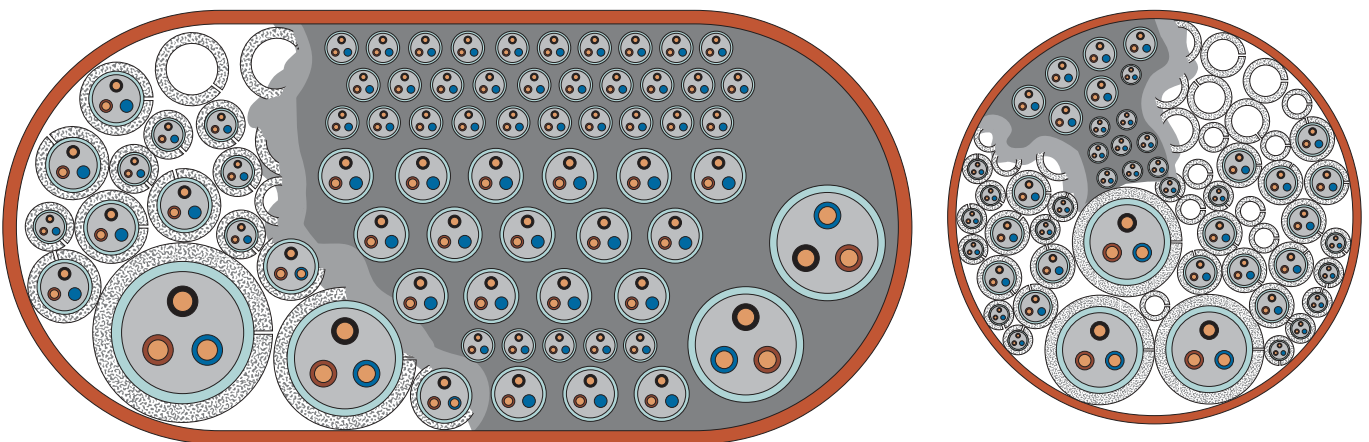

***most compact installation ever with a
RISE[®] multi-cable penetration***

RISE[®]

MULTI-CABLE PENETRATIONS

**fire tested with insulation at one side only
in accordance with IMO Res. A.754(18)**

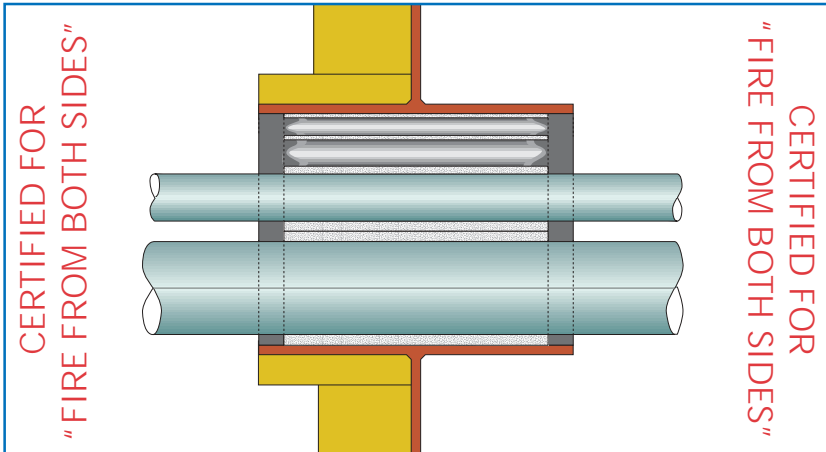

Section A.IV/2.2.1 of IMO Res. A.754(18) states "A bulkhead which includes the cable transit should be constructed in accordance with 2.1.1 of the recommendation and **should be insulated to class A-60 on the stiffened side, which should be the face which is not exposed to the heating conditions of the test.**" Systems tested with insulation at the exposed side have a limitation in the application. The bulkhead must then be totally insulated at both sides! This is not the case with RISE[®].

**shortest possible conduit length, less
insulation with RISE[®] multi-cable penetrations**

**fire tested in worst case scenarios
in accordance with IMO Res. A.754(18)**

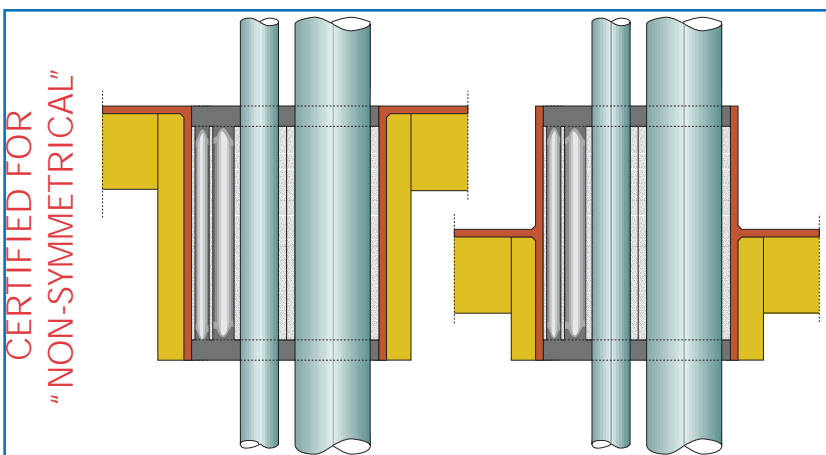

The easiest way to pass a deck test is to place the transit totally above deck. **Worst case for deck penetrations is to place the transits totally below deck.** And that is exactly the way the penetrations generally are installed! Cable penetrations should be applied as tested. This means that penetrations tested only above deck should not be placed totally below deck. RISE[®] multi-cable penetrations are tested "worst case" and can be welded in above, below, midway.

**any position of the transits will do for
a RISE[®] multi-cable penetration**

RISE[®]

MULTI-CABLE PENETRATIONS

RISE[®] materials lengthen the penetration when exposed to heat or flames

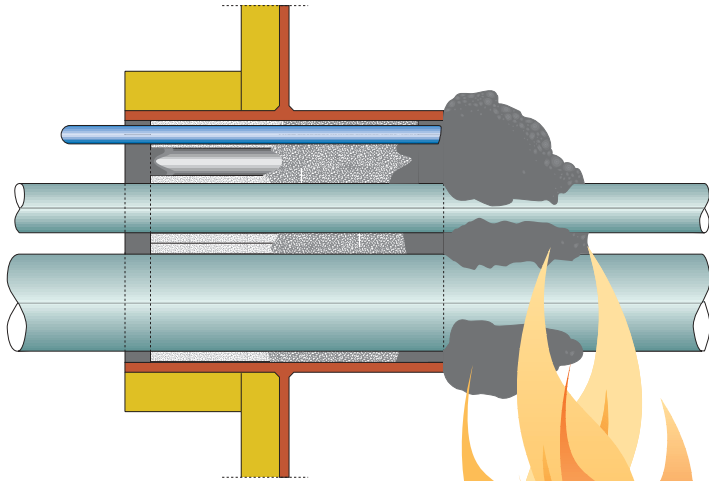

All classes above A-0 or H-0 must have a T-rating (not exceeding 180 °C/400 °F at the unexposed side). **For every technician it will be clear that when ducting cables containing a lot of copper, the length of the penetration is a determining factor here.** RISE[®] cable penetrations have been tested with heavy conductor cables. The length of the conduit could be minimized by the use of the expanding sealant/rubber, which lengthen the penetration when exposed to fire.

no fussing with extra insulation in front of the penetration and in between the cables

RISE[®] materials expand massively when exposed to heat or flames



Generally, rubbers used for multi-cable transit systems are made of a more or less self-extinguishing compound. The drawback, however, is that these rubbers will start charring under heat and slowly but surely will shrink due to the loss of the water content in the rubber. **Not with RISE[®]!** The rubber starts vulcanizing when exposed to heat, forming a solid rubber mass inside the penetration and an expanding char on all exposed surfaces.

all gaps will be filled automatically by the “self-correcting” RISE[®] cable penetration

RISE[®]

MULTI-CABLE PENETRATIONS

***approved gas and water tight
RISE[®] multi-cable penetrations***

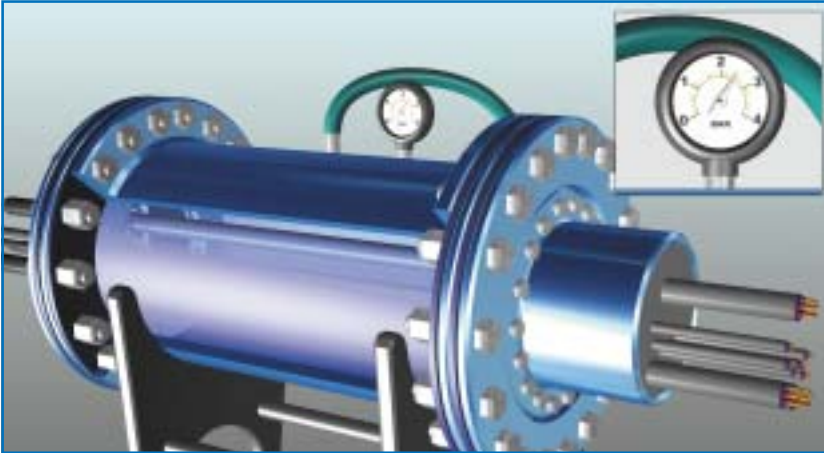

Due to the high bonding strength and flexibility of the FIWA[®] sealant, the penetrations could be subjected to certified pressures up to 2.5 bar (35 Psi) without any leakage. Where rubber parts of systems have to be strongly compressed to obtain watertightness, they will soon show permanent deformation. Also, the cable sheathings are exposed to this heavy load and will creep. This is not the case with RISE[®]. ***Tight stays tight, with no compressive forces on the cables! CERTIFIED.***

***no compression needed to obtain a watertight
RISE[®] multi-cable penetration***

***RISE[®] cable penetrations are artificially
aged for a service life up to 50 years***



What will the performance of a fire safe multi-cable penetration be after years of service? ***Remember that safety is at stake here.*** This is the reason why the RISE[®] system has been artificially aged up to 50 years, after which the expanding properties of the rubber and the sealant were compared with new material. Only minor changes were noted! Temperature cycle on the RISE[®] system from -40 °C to ambient to +120 °C, and back, showed that the adhesion of FIWA[®] holds the system tight!

***RISE[®] multi-cable penetrations are exposed to
thermal cycling tests with positive results***

RISE[®]

MULTI-CABLE PENETRATIONS

additional safety with RISE[®] multi-cable penetrations

| | |
|--|----------|
| * Naval Engineering Standard 711: Issue 2: Determination of the smoke index | passed |
| * Naval Engineering Standard 713: Issue 3: Determination of the toxicity index | passed |
| * ISO 4589 - 2 : 1996 Determination of the oxygen index | passed |
| * ISO 4589 - 3 : 1996 Determination of the temperature index | passed |
| * IMO Resolution A.653(16) Determination of low flame spread characteristics | passed |
| * Artificial ageing test Determination of properties after 25-50 years | passed |
| * Thermal cycling test Determination of adhesion at +120 °C / ambient / -40 °C (+212 °F / ambient / -40 °F) | passed |
| * Naval Engineering Standard 510: Issue 2, Draft B: Shock (100 g _y) and vibration test (5-350 Hz) combined with 1 bar leak test afterwards | passed |
| * Naval Engineering Standard 814: Shock test, acceleration level 8378/s/s in two directions combined with 6.9 bar leak test afterwards | passed |
| * Naval Engineering Standard 510: Issue 2, Draft B: Leak test after a one hour fire test | passed |
| * DNV classification A-0 test without insulation of the deck/bulkhead | passed |
| * General classification Helium gas leak test up to 1 bar | passed |
| * Nordtest method NT ELEC 030, modified for conducted attenuation | 20-85 dB |
| * Sound damping test According to EN ISO 717-1:1996 | 70 dB |
| * Rapid rise fire test According to Mil-P-24705 of the US Navy | passed |
| * Dynamic cycling test Displacement 10 mm, 100,000 cycles, frequency 0.5 Hz | passed |

To prove the outstanding quality and safety of the RISE[®] multi-cable penetrations, the basic materials (FIWA sealant and FRR/LEHF rubber) have been subjected to additional tests.

These tests have been carried out by official institutes: Warrington Fire Research and RAPRA Technologies in the United Kingdom, the Fire Technology Institute of the University of Ghent in Belgium and TNO Laboratories in The Netherlands.

The RISE[®] cable and pipe penetrations have also been subjected to additional tests at official institutes such as DELTA Danish Electronics, Light and Acoustics Testing in Denmark, DERA in England, South West Research Institute in USA and in-house under survey of the classification societies.

To name some: sound tests, shock and vibration tests, rapid temperature rise tests, leak tests after a one hour fire test, EMC tests, A-0 test without insulation, dynamic cycling test, several configurations on watertightness and a helium gas leak test.

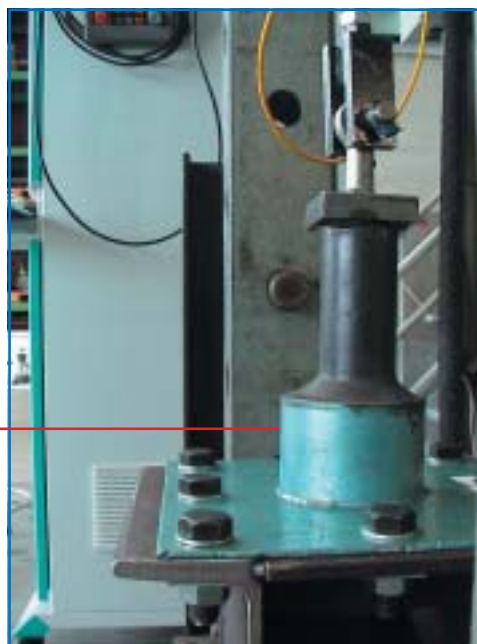

RISE[®] has been exposed to shock tests up to 850 g and a dynamic cycling test of 100,000 cycles at one cycle every two seconds with a displacement of 10 mm without showing any damage.

**THE HIGH TECH
SEALING SYSTEM**



RISE[®]

MULTI-CABLE PENETRATIONS

**approved A0-A60 and H0-H120 class
RISE[®] multi-cable penetrations**



Sometimes it is most confusing to figure out how systems should be applied in an A- or an H-class division.

Since the procedures for fire testing penetrations for these classes only differ from the time/temperature curve, we figured out that the only difference in the construction of the RISE[®] penetration should be the length of the conduit.

So, it's that simple: for A-class conduit 200 mm (8") and for H-class 250 mm (10").

RISE[®] sealing system: EC approved.

**same basic materials, no extras for an
A- or H-class RISE[®] multi-cable penetration**

**stamped installation drawings for
RISE[®] multi-cable penetrations**

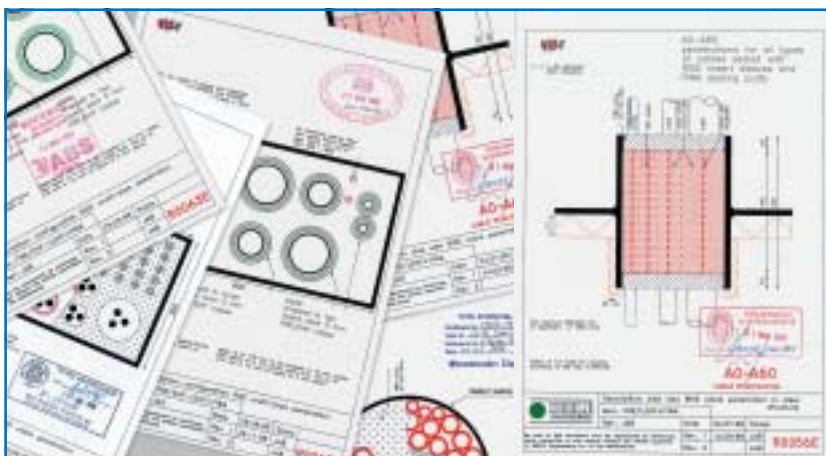

Due to the severe method of testing with the conduit welded symmetrically, totally on the exposed side and totally on the unexposed side of the deck/bulkhead, it is now a simple matter to decide how to position the unit.

For RISE[®] it doesn't matter if you only have space available on the fire side or on the unexposed side. A RISE[®] multi-cable penetration will function in all possible scenarios. Period.

RISE[®]: constructional advantages.

**no time-consuming discussions about
"how to apply" with RISE[®] cable penetrations**

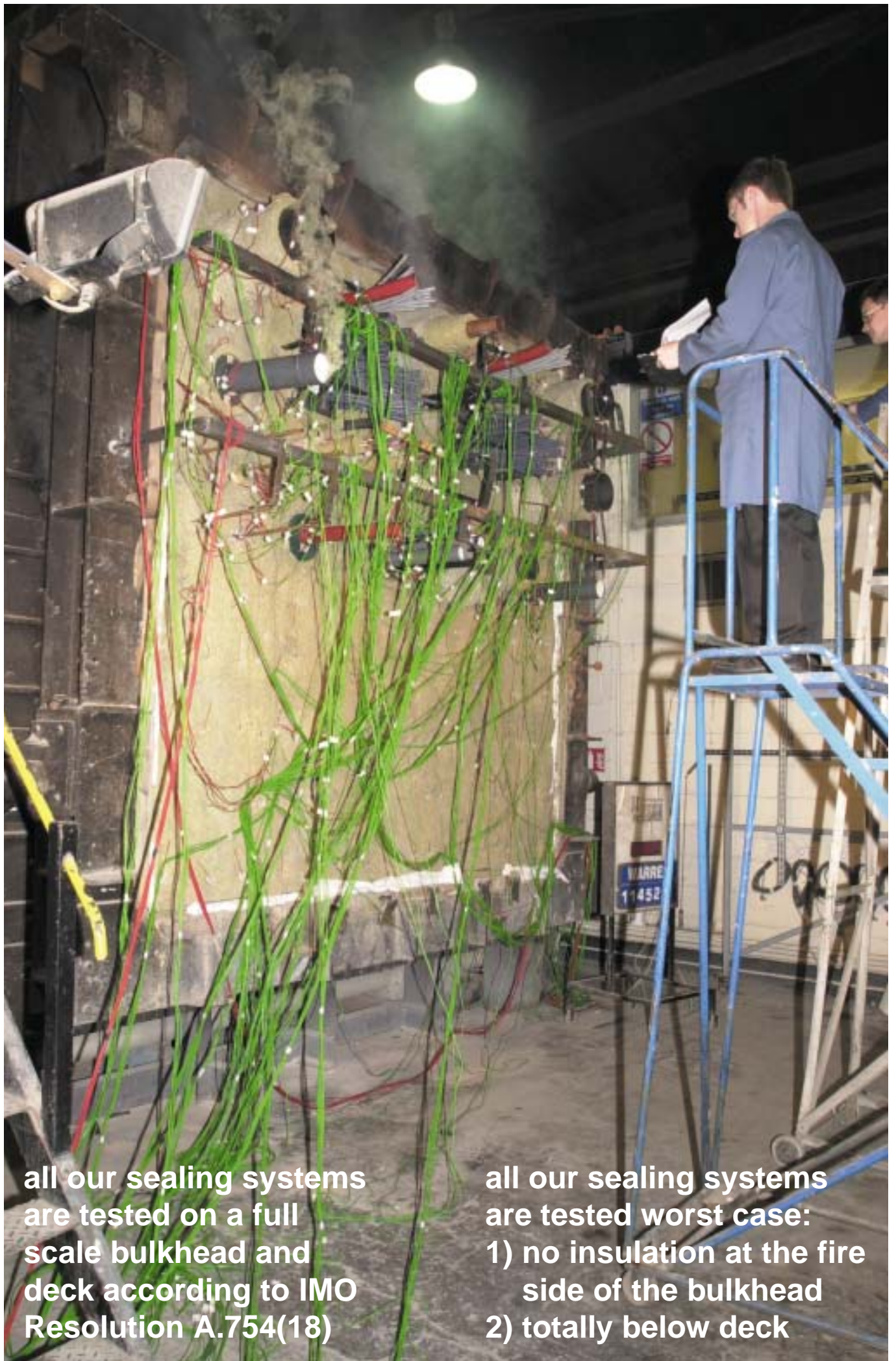

**all our sealing systems
are tested on a full
scale bulkhead and
deck according to IMO
Resolution A.754(18)**

**all our sealing systems
are tested worst case:
1) no insulation at the fire
side of the bulkhead
2) totally below deck**

CERTIFIED BY:

American Bureau of Shipping

Bureau Veritas

China Classification Society

China Corporation Register of Shipping

Det Norske Veritas

Germanischer Lloyd

Korean Register of Shipping

Lloyd's Register of Shipping

Nippon Kaiji Kyokai

Registro Italiano Navale

Transport Canada

US Coast Guard

Approval certificate according to NES 510 Issue 1, Number DERA/EL/WLSD/TMS/30/13/003 has been issued by the DEFENCE EVALUATION AND RESEARCH AGENCY (DERA) of the MINISTRY OF DEFENCE/UNITED KINGDOM.

US Navy Approval Letter 9300 9342/Ser085 issued by Naval Surface Warfare Center, Carderock Division, based on fire tests performed in accordance with MIL-P-24705.

EC certificates according to EUROPEAN UNION COUNCIL DIRECTIVE 96/98 EC on MARINE EQUIPMENT have been issued by BUREAU VERITAS, certificates N° 10035/A4 EC and N° 10710/A1 EC for single and multi-pipe penetrations for metallic and plastic pipes, N° 09156/A6 EC for multi-cable penetrations and extended multi-cable penetrations and N° 11301/A0 EC for EMC multi-cable penetrations.



ASSEMBLY INSTRUCTIONS RISE® MULTI-CABLE PENETRATIONS

(available on video)

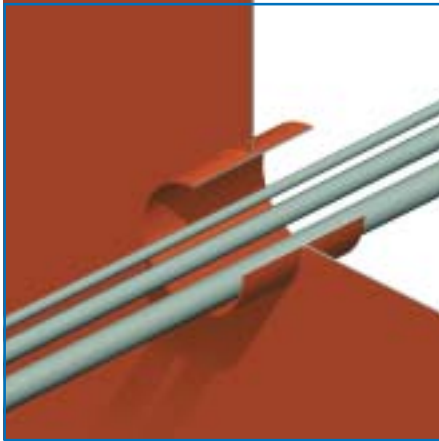

1) The cables can be ducted through the conduit sleeve/frame in random order. It is most important that they are not pulled too tight in order not to hamper their separation at a later stage.

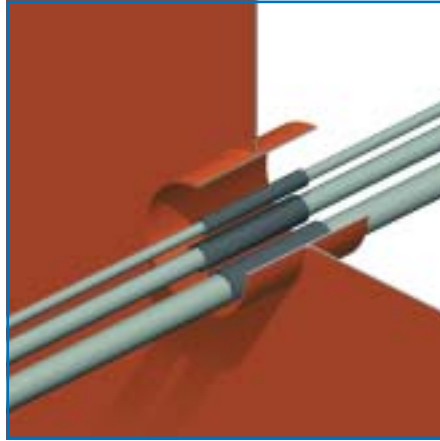

2) After the cables have been ducted, a RISE® insert sleeve is applied around each cable. The insert sleeves are split length-wise and can therefore be fitted around the cables in front of the conduit.

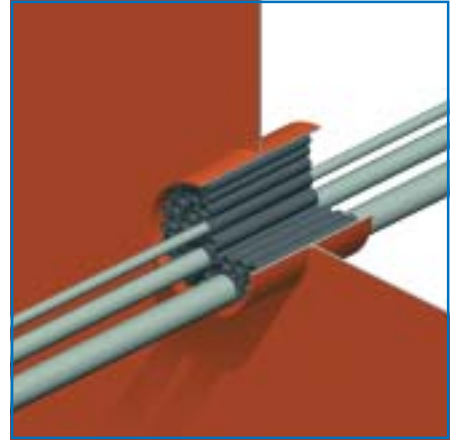

3) The remaining free space in the conduit is filled with RISE® filler sleeves type 27/19 and 18/12.

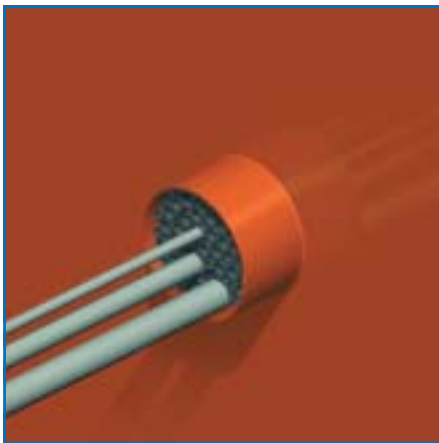

4) Push the insert/filler sleeves into the conduit in such a way as to leave about 20 mm (.8") free space at the front.



5) A 20 mm (.8") thick layer of FIWA® sealant is applied at each side of the conduit. Clean and dry the conduit opening thoroughly and remove any dirt, rust or oil residues before applying the sealant.

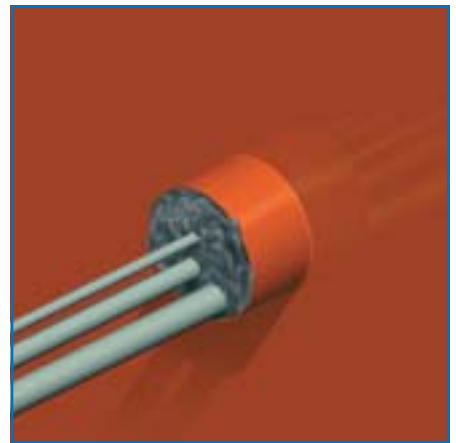

6) The conduit should be overfilled with FIWA® sealant, because some sealant will be pushed between and into the empty insert sleeves during further finishing.



7) To smooth the surface of the FIWA® sealant layer, a cloth is sprayed with soapy water. This prevents the sealant from sticking to the cloth.

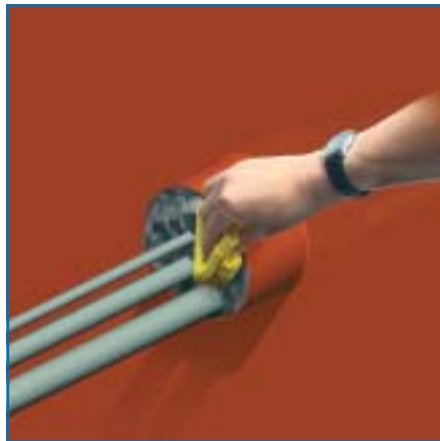

8) The cloth is then used to press down the sealant layer. People with sensitive skin should use gloves when working with the FIWA®. Please refer to the Safety Data Sheet for more information.

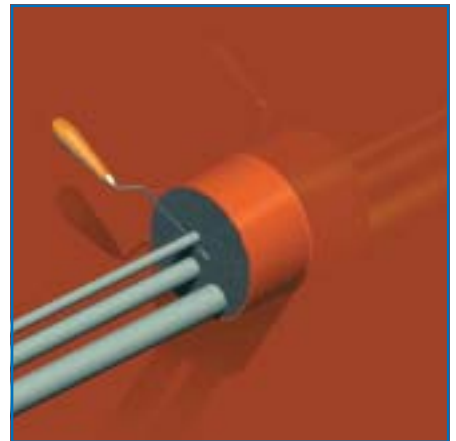

9) The FIWA® sealant between the cables is pressed down and smoothed with a spatula or putty knife. This is essential to obtain an effective gas- and water tightness.

ASSEMBLY INSTRUCTIONS RISE® MULTI-CABLE PENETRATIONS (available on video)



10) The surface can also be smoothed by hand. Just wet the hand thoroughly with soapy water. People with sensitive skin should use gloves when working with the FIWA®.

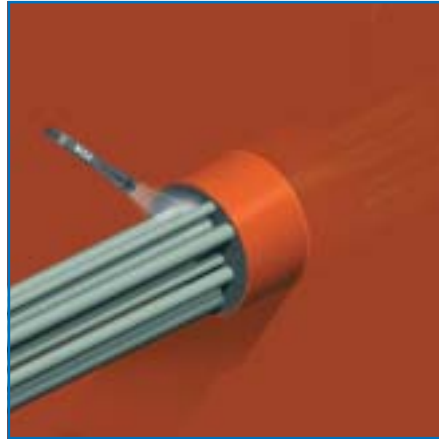

11) After smoothing is finished a last check should be taken if sufficient sealant is applied in between the cables especially at penetrations with larger amounts of cables.

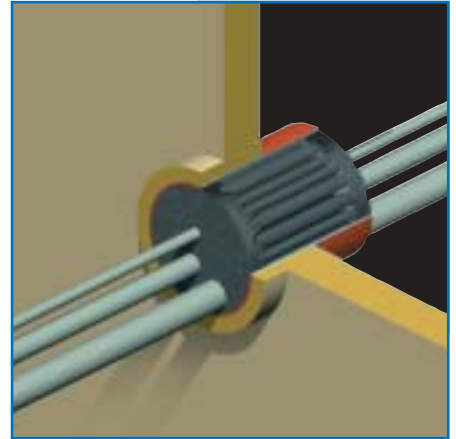

12) For A-class penetrations the conduit sleeve/frame needs to be insulated only at the insulated side of the bulkhead or at the lower side of the deck. **No extra insulation needed in front of the penetration and/or in between the cables.**

RISE® MULTI-CABLE PENETRATIONS ARE EASY TO INSTALL EVEN IN VERTICAL CABLE RUNS.

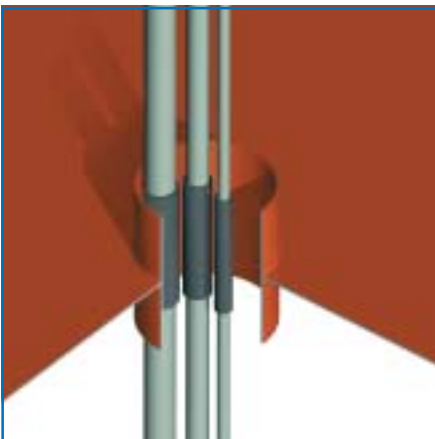

Due to the length of the insert sleeves, they cling to the ducted cables in such a way that they are prevented from sliding down.

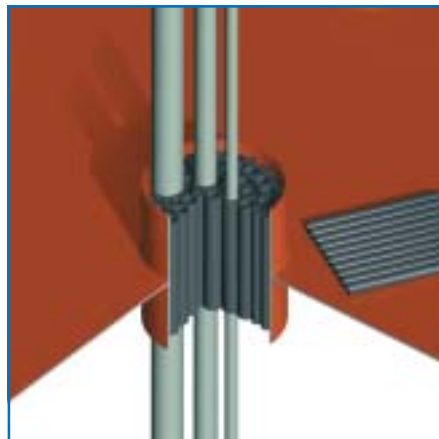

To prevent the filler sleeves from falling out of the conduit sleeve/frame, they are bundled together to form a compact bundle. They are available in bundles of ten pieces. Single filler sleeves are also available non-split.

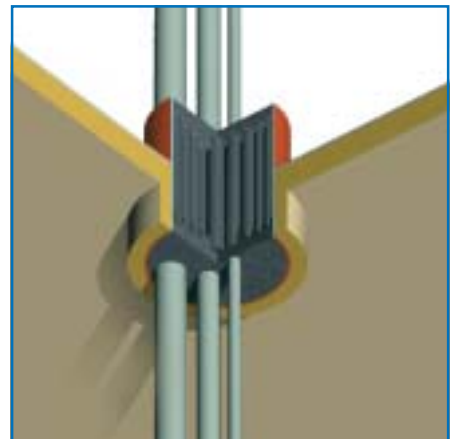

The superb adhesion properties and the viscosity of the FIWA® sealant make applying the sealant overhead an easy matter.



The only tools and accessories needed to finish the conduit are a compound gun, a flower spray, a trowel, a small spatula, some soap and a cloth.

This means that material management and installation are simple matters.

The large adhesive power of FIWA® sealant requires the cloth and the tools to be wetted regularly with soapy water during installation.

free instruction video of the installation of RISE® cable and pipe penetrations available

RISE[®]

MULTI-CABLE PENETRATIONS

DIAGRAMMATIC OVERVIEW OF SHIPBUILDING/ OFFSHORE APPLICATIONS

- L1: A-60/H-120 approved bulkhead insulation.
- L2: mineral wool minimum 25 mm, density 110 kg/m³ for A-class penetrations or equivalent; for H-class penetrations ceramic fibres 128 kg/m³ or equivalent as used for the bulkhead insulation.

- NO EXTRA INSULATION REQUIRED AT THE FRONT OF THE PENETRATION AND/OR IN BETWEEN THE CABLES

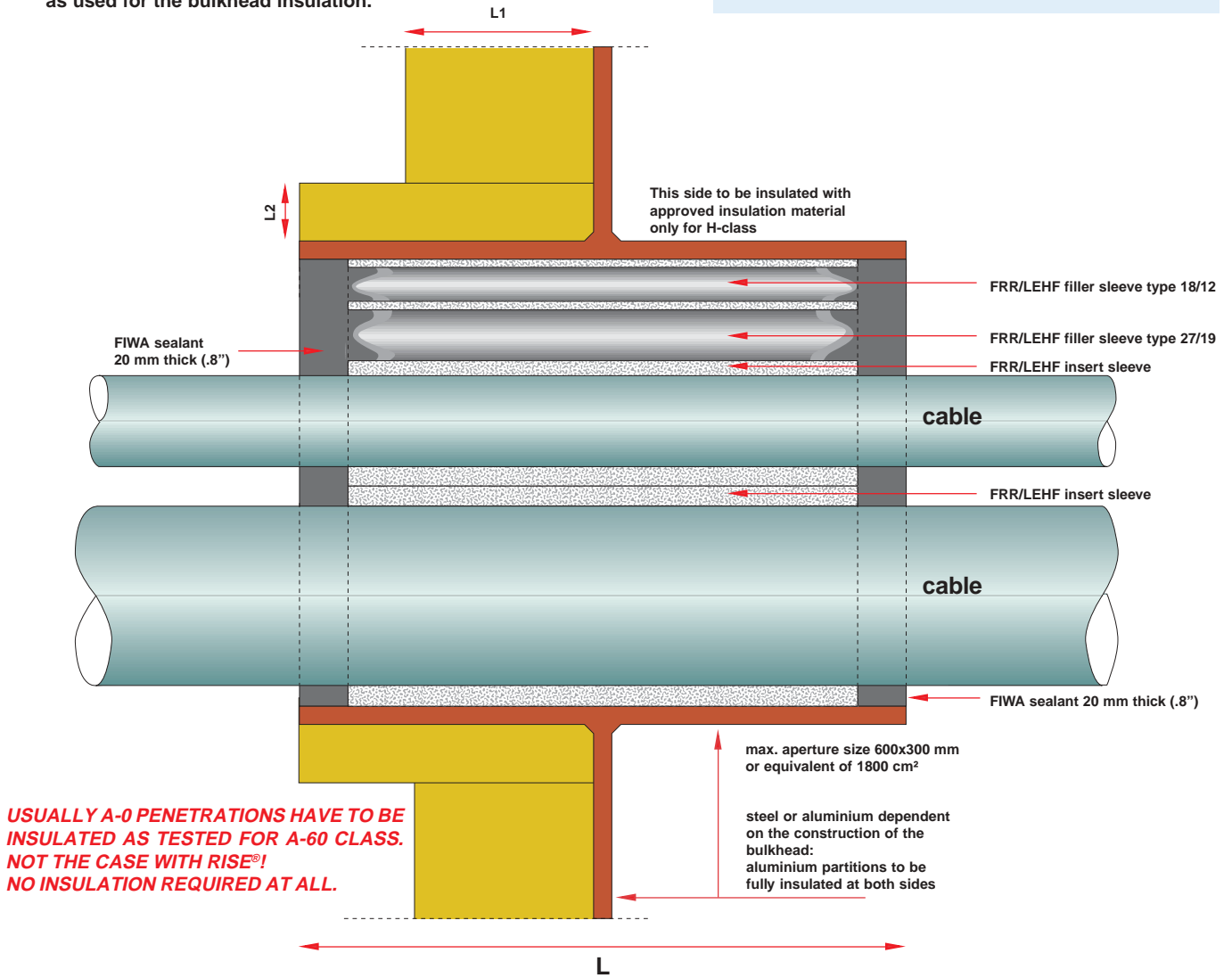

L = 200 mm (8") for A-class and 250 mm (10") for H-class

specifications for A-class according to CE certificate 09156/A6 EC issued by Bureau Veritas

length of the RISE[®] insert and filler sleeves 160 mm (6.30") for A-class and 210 mm (8.27") for H-class.

For watertight penetrations only see page 33;
for B-15 class penetrations see page 34

A0-A60 / H0-H120 CABLE PENETRATION BULKHEADS

MULTI-CABLE PENETRATIONS

DIAGRAMMATIC OVERVIEW OF SHIPBUILDING/ OFFSHORE APPLICATIONS

- L1: A-60/H-120 approved deck insulation.
- L2: mineral wool minimum 25 mm, density 110 kg/m³ for A-class penetrations or equivalent; for H-class penetrations ceramic fibres 128 kg/m³ or equivalent as used for the deck insulation.

- NO EXTRA INSULATION REQUIRED AT THE FRONT OF THE PENETRATION AND/OR IN BETWEEN THE CABLES

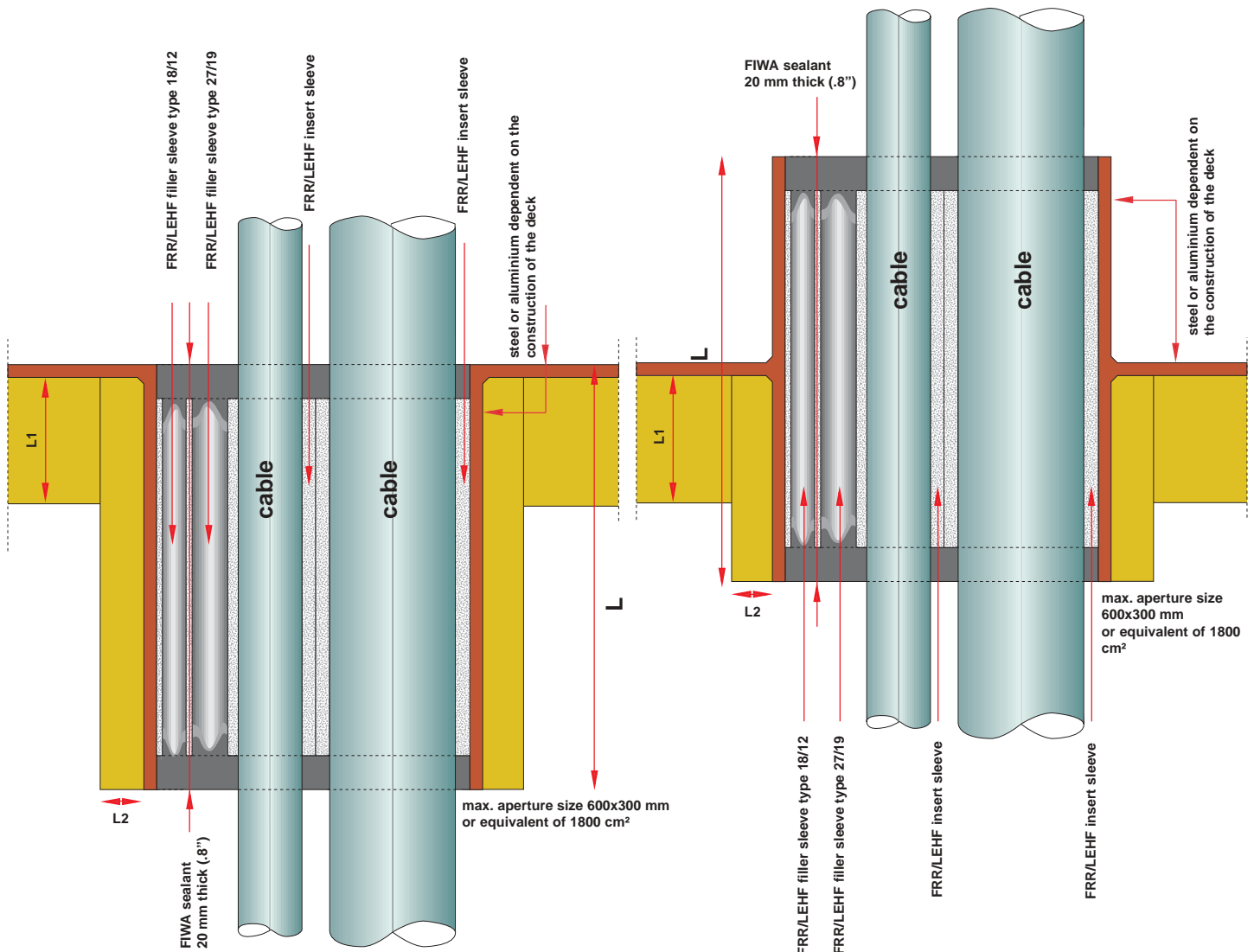

**L = 200 mm (8") for A-class and
250 mm (10") for H-class**

length of the RISE® insert and filler sleeves 160 mm (6.30") for A-class and 210 mm (8.27") for H-class.

*For watertight penetrations only see page 33;
for B-15 class penetrations see page 34*

specifications for A-class according to CE certificate 09156/A6 EC issued by Bureau Veritas

**A0-A60 / H0-H120
CABLE PENETRATION
DECKS**

INSTRUCTIONS FOR UPGRADING MULTI-CABLE TRANSITS WITH RISE®

Existing installations can easily be upgraded to the RISE® sealing system using extension frames. Generally the depth of the transit frames is too short to offer the required thermal insulation during a fire. To fulfil this criterion for all types of cables a minimum depth of 200 mm (8") is an absolute must. Otherwise the transit and the front side of the penetration have to be totally insulated. By making use of extension frames the required depth can easily be obtained.

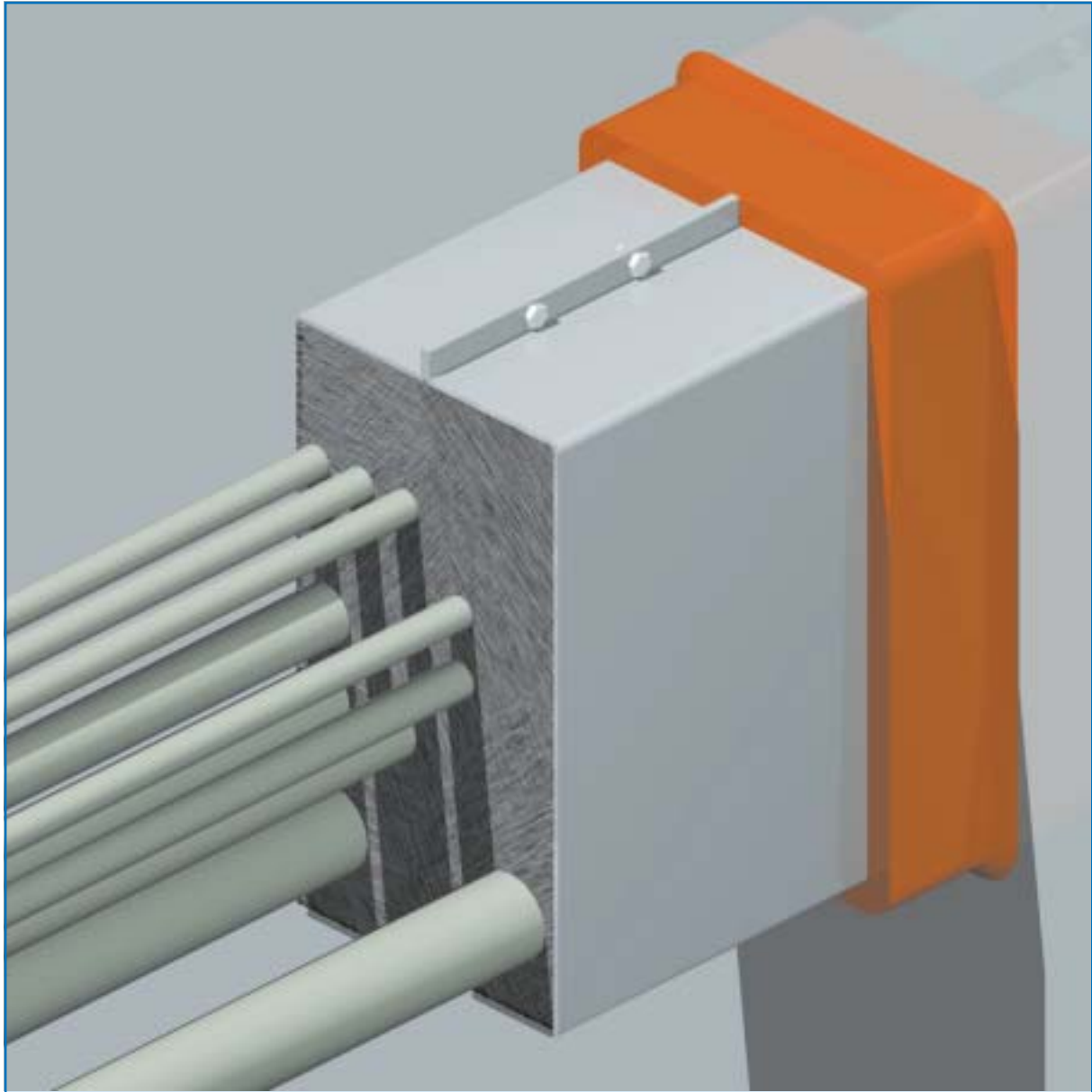

*The advantage of upgrading with RISE® is not only an improvement of the fire rating, but it also gives the option to acquire more available space for ducting extra cables. The extended RISE® penetration filled with the same configuration of cables as tested with the normal RISE® penetrations and with the same sizes, has been successfully tested according to IMO Resolution A.754(18) for use in both A0 - A60 class bulkheads and decks. **CE certificate N° 09156/A6 EC.***

***RISE® EXTENDED successfully tested
to IMO Resolution A.754(18)***

INSTRUCTIONS FOR UPGRADING MULTI-CABLE TRANSITS WITH RISE®

Remove all block components from the transit frame, if any. Remove any dirt or grease from the inside of the frame. Position the two halves of the EXTEND-A-FRAME around the bundle of cables, then push the EXTEND-A-FRAME into the transit frame. The fitting must be very tight for stability reasons. The flanges on the top and bottom of the EXTEND-A-FRAME must be firmly seated against the transit frame. Install the bolts and nuts on the top and bottom flanges.

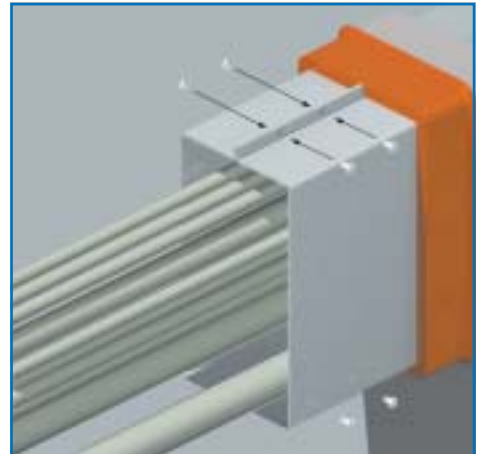
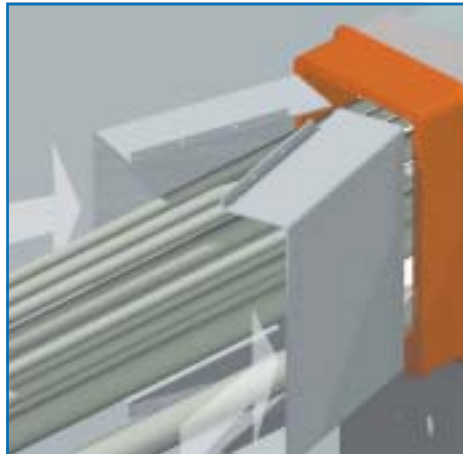

FOR OPTIMUM STABILITY IN CASE OF FIRE, THE EXTEND-A-FRAME SHOULD BE SPOT WELDED TO THE EXISTING TRANSIT FRAME

Tighten the bolts on top and bottom flanges. The flanges are 10 mm (.4") high, corresponding with the wall thickness of the block system transits. This enables the EXTEND-A-FRAMES to fit in multi-transit units without any problems. The EXTEND-A-FRAME, positioned in the transit frame, leaves 20 mm free at the back of the transit frame for the bonding of the FIWA® sealant to that transit frame. This is necessary to obtain a tight seal.

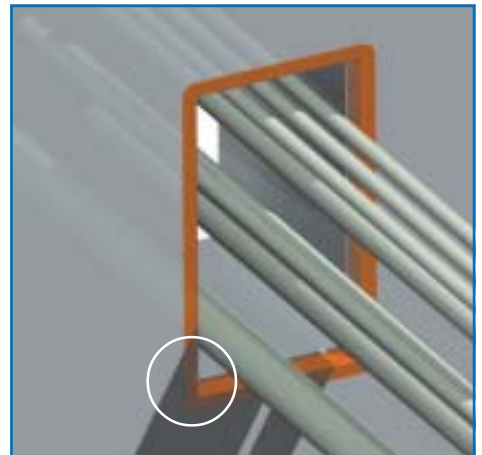
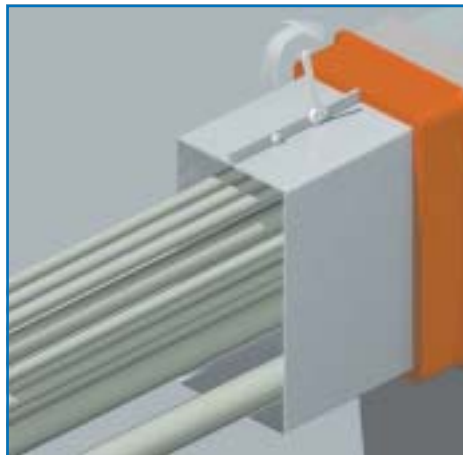

ANOTHER OPTION IS TO INSTALL A FRAME AROUND THE EXISTING TRANSIT FRAME SPOT WELDED TO THE DECK OR BULKHEAD

Place a RISE® insert sleeve around each cable. Center the RISE® sleeves within the conduit so as to leave 20 mm (.8") free space at the front and the back of the transit.

Any empty space is filled with RISE® filler sleeves. A 20 mm (.8") layer of FIWA® sealant is applied at both sides of the transit. Refer to the step by step installation instructions for RISE® multi-cable penetrations for final finishing of the transit. A perfect tight seal is obtained by applying FIWA® sealant inside the block transit frame.

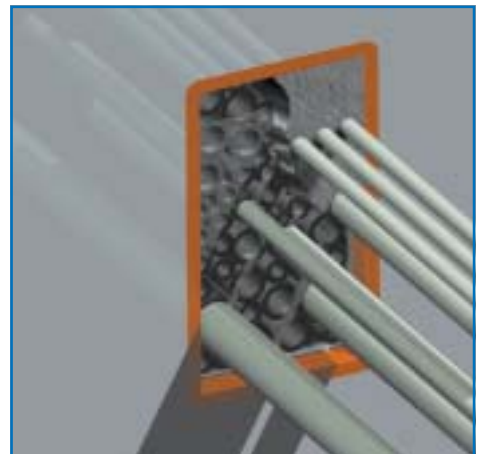
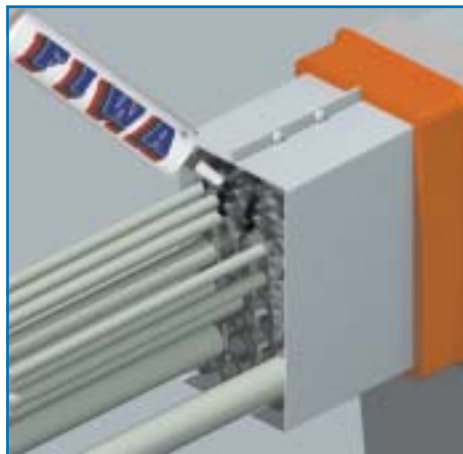

***instantly doubles the usable space inside
any block system transit frame***

RISE[®]-EXTENDED MULTI-CABLE PENETRATIONS

DIAGRAMMATIC OVERVIEW OF SHIPBUILDING/ OFFSHORE APPLICATIONS

L1: A-60 approved bulkhead insulation.

- NO EXTRA INSULATION
REQUIRED AT THE FRONT
OF THE PENETRATION
AND/OR IN BETWEEN THE
CABLES

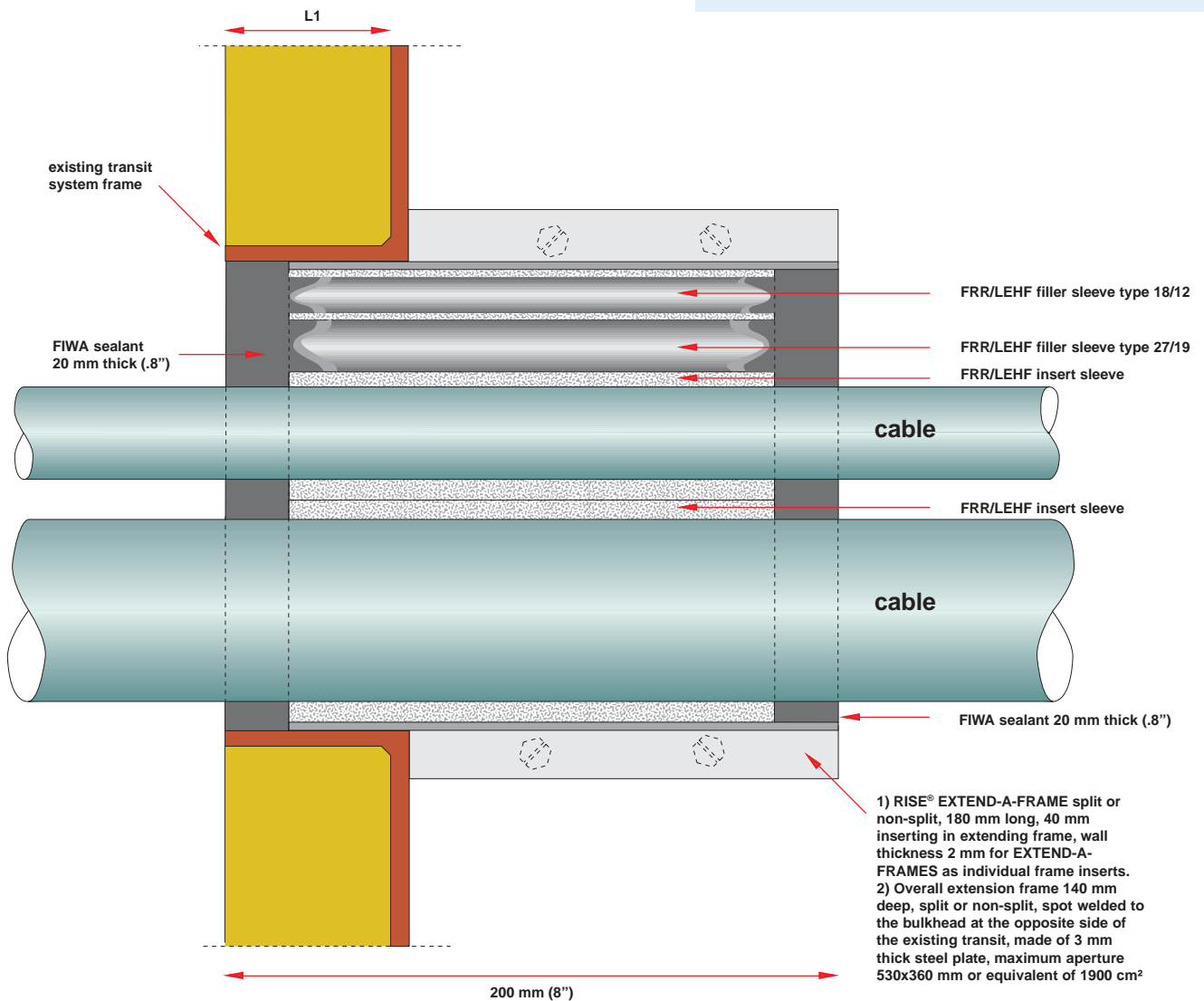

specifications according to CE certificate
09156/A6 EC issued by Bureau Veritas



**A0-A60
CABLE PENETRATION
BULKHEADS**

RISE®-EXTENDED MULTI-CABLE PENETRATIONS

DIAGRAMMATIC OVERVIEW OF SHIPBUILDING/ OFFSHORE APPLICATIONS

- L1: A-60 approved deck insulation.
- L2: mineral wool minimum 25 mm, density 110 kg/m³ or equivalent.

**- NO EXTRA INSULATION
REQUIRED AT THE FRONT
OF THE PENETRATION
AND/OR IN BETWEEN THE
CABLES**

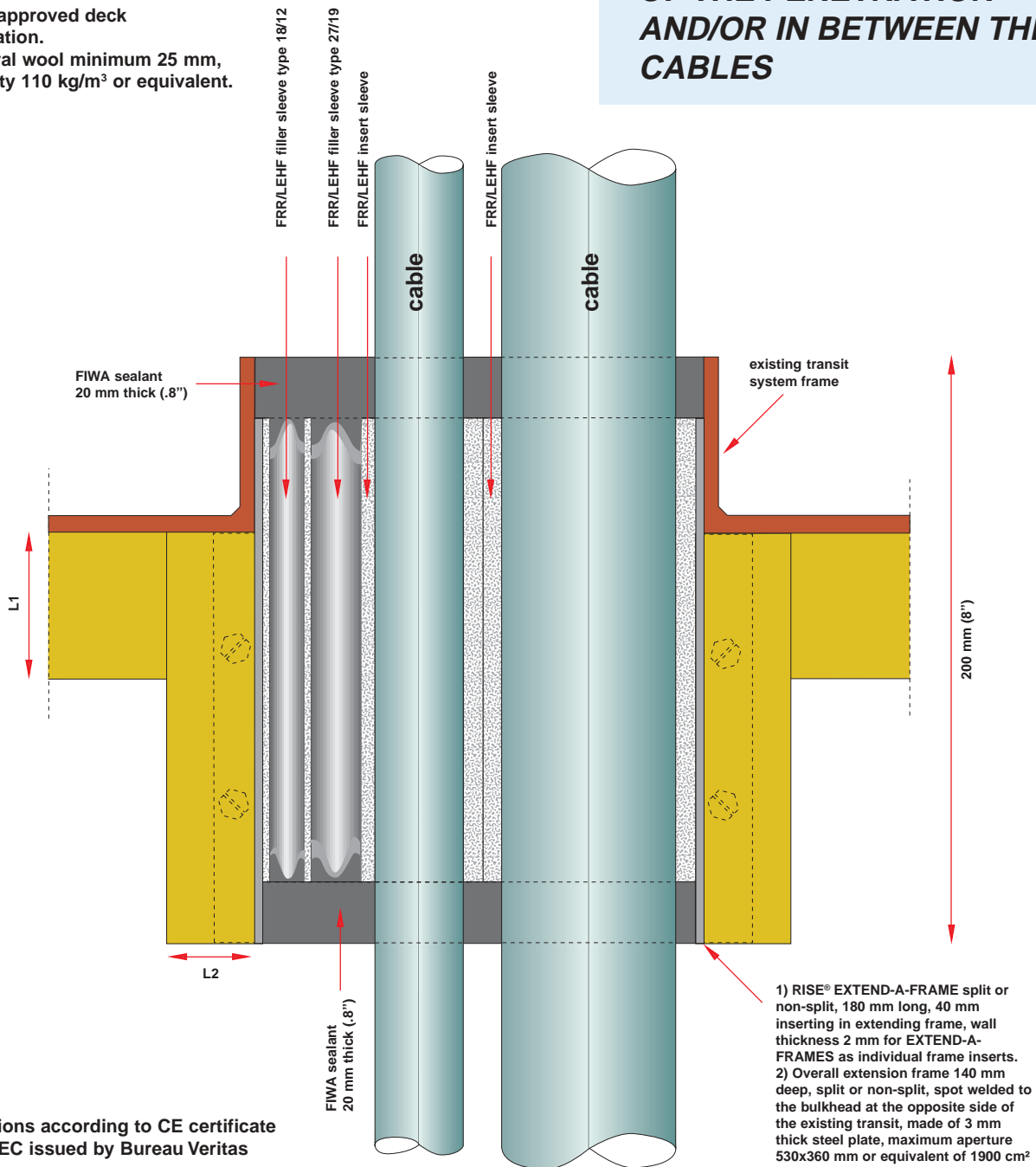

specifications according to CE certificate
09156/A6 EC issued by Bureau Veritas



A0-A60 CABLE PENETRATION DECKS

RISE® B-15 CLASS MULTI-CABLE PENETRATIONS

No special requirements for B-class bulkhead cable penetrations are addressed in IMO Resolution A.754(18).

The performance criteria for B-class divisions are specified in section 9.1.2 of IMO Resolution A.754(18).

The allowable temperature rise on the unexposed side of these divisions is 225 °C above initial temperature. The duration of the fire test is limited to 15 minutes. Due to the higher margin in thermal insulation and the shorter duration of the fire test, the RISE® multi-cable penetrations can be shorter in length, whereby the frame can be made of light weight steel plate of only 3 mm thickness. Frame can be split or non-split.

Use is made of 40 mm long insert sleeves with 20 mm FIWA® sealant applied only at one side.

LRS certificate

APE 0009220/1.

Watertightness 1.5 bar:

LRS certificate

APE 0109444.

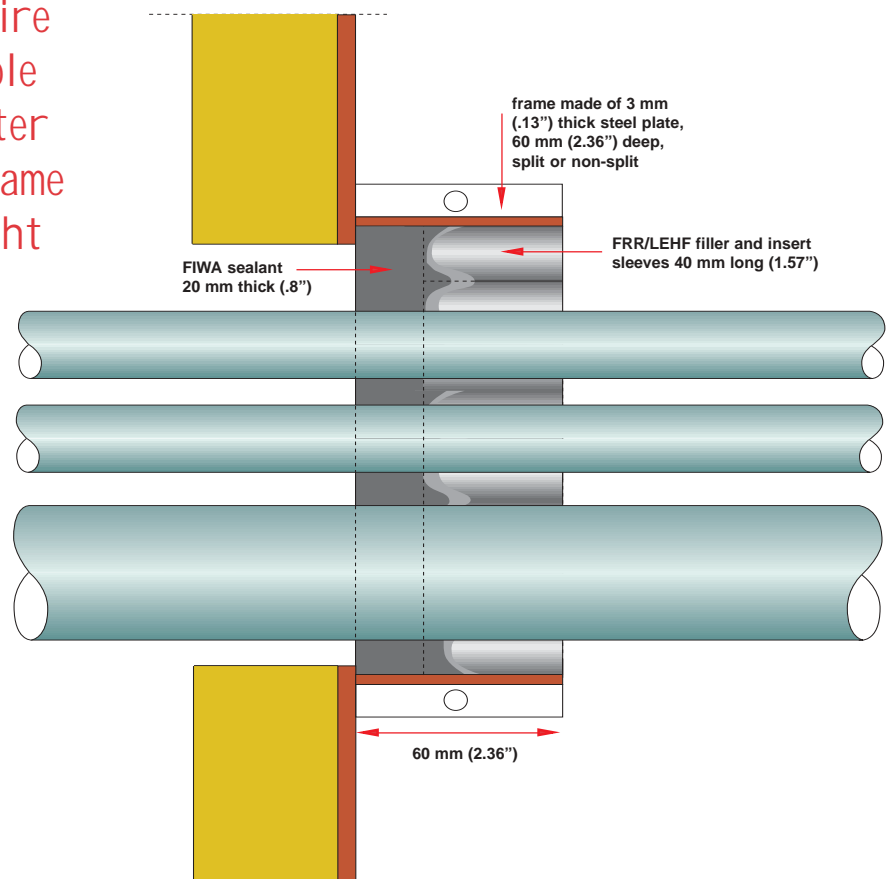
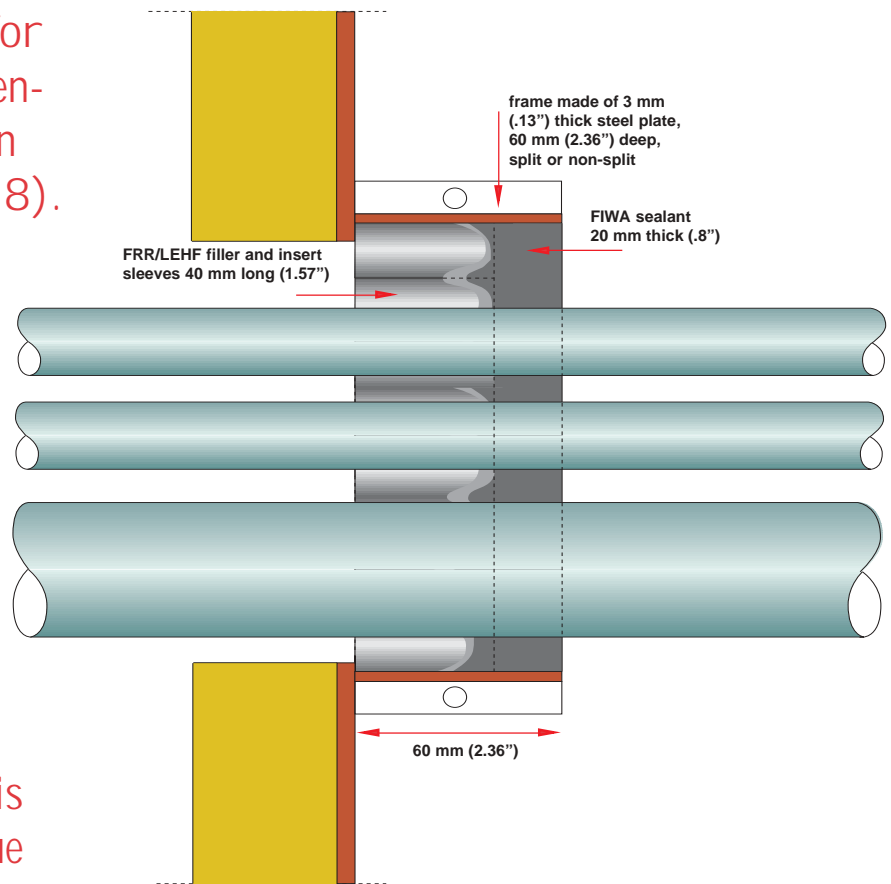

INSTRUCTIONS FOR LATER EXTENSIONS OF THE CABLE SET



1) If circular profiles to mark the position of empty sleeves are not present, it is impossible to determine precisely where the empty insert sleeves are.

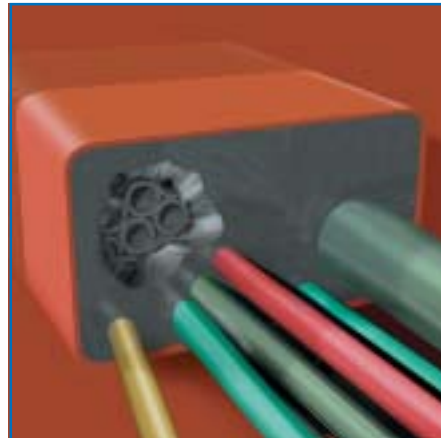

2) Cut away the sealant layer at both sides of the penetration with a knife or a hollow punch in a tapering shape as shown above. This creates a good foundation for the sealant mass to be applied later.

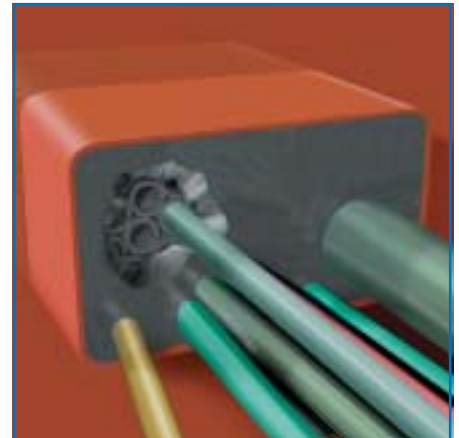

3) Pull the cable through one of the empty sleeves with an inner diameter more or less corresponding to the outer diameter of the cable.



4) If the empty insert sleeves are not fitting to the size of the cable to be ducted, a number of these insert sleeves must be removed from the penetration.



5) Install a fitting insert sleeve (with some empty sleeves if necessary) in the open space in the penetration.



6) Pull the cable through the fitting insert sleeve that has now been installed.

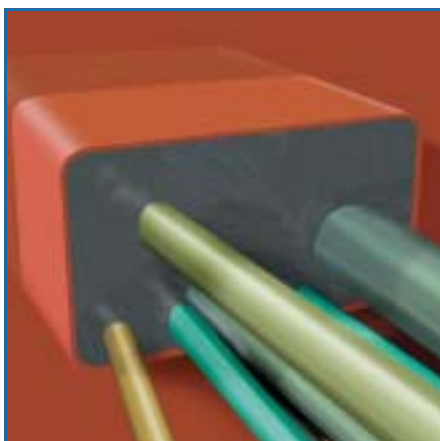

7) Refill the openings cut in the sealant layer at both sides of the penetration with sufficient FIWA® sealant. The FIWA® sealant is pressed down firmly and smoothed with a damp cloth.



If future extensions of the cable set are expected, measures to deal with this can be taken when assembling the RISE® cable penetration. The position of anticipated future cables is

| profile type | profile length | sleeve type |
|--------------|----------------|-------------|
| FRR/HF 7 | 500 | 12/6 |
| FRR/HF 9 | 500 | 14/8 |
| FRR/HF 11 | 500 | 16/10 |
| FRR/HF 13 | 500 | 18/12 |
| FRR/HF 15 | 500 | 20/14 |
| FRR/HF 17 | 500 | 22/16 |
| FRR/HF 21 | 500 | 27/19 |
| FRR/HF 25 | 500 | 31/23 |
| FRR/HF 29 | 500 | 35/27 |
| FRR/HF 33 | 500 | 39/31 |
| FRR/HF 39 | 500 | 46/36 |
| FRR/HF 45 | 500 | 52/42 |
| FRR/HF 51 | 500 | 58/48 |
| FRR/HF 57 | 500 | 64/54 |
| FRR/HF 63 | 500 | 70/60 |

marked by means of FRR/HF (fire resistant rubber/halogen free, trade mark FIRUB/NOHAL®) circular profiles. A RISE® insert sleeve is fitted around each of the FRR/HF circular profiles.

RISE® TYPE EMC PENETRATIONS FOR EMP/EMI PROTECTION

Interference sources such as laser equipment, relays, computer terminals, radar, lightning or NEPM can generate magnetic or electric fields. The induced interference currents are capable of affecting the performance of equipment fitted with sensitive microelectronics, such as control systems, process computers and electronic data processing systems and even causing failure of that equipment. It is therefore vital to shield microelectronic equipment against these interference currents. In areas where major

electronic systems have to be installed, structural measures are taken with a view to safeguarding against the risks of disturbances in electronic components caused by electromagnetic fields. A Faraday cage is created by installing special shielding steel structures around the space.

Pipes entering such shielded spaces perforate the protective screen provided and, if no measures are taken, are capable of conducting electromagnetic pulses and fields into the shielded area.

For the EMC protection of cable penetrations entering shielded areas, BEELE Engineering has developed an electrically conductive sealant/flexible rubber and rubber tape/sleeves for the RISE® multi-cable penetrations type EMC. Tests carried out in our laboratories have shown that the electrical surface resistance is less than 100 ohm. Attenuation tests at DELTA Electronics Testing/Denmark have proven the outstanding damping properties of the RISE® EMC sealing system: 35-85 dB.

UV and ozone resistant.

Gas and water tight.

Fire safe.

CE certificate 11301/A0 EC.



In case the penetrations have to be only EMC proof, the length of the conduit can be reduced substantially. Only 40 mm CONDUCTON® putty/flexible rubber or CONDUCTON® tapes and sleeves for the conductive filling of the cavity in between the layers of FIWA® sealant can be used. The CONDUCTON® flexible rubber is most easy to apply. The attenuation with the flexible rubber is the optimum; the attenuation of the tape/sleeves is equal but shows more fluctuation.

**Test report DELTA-K221274-2:
Attenuation 20-60 dB**

**Test report DELTA-K221736-1:
Attenuation 35-85 dB**

The newly developed EMC rubber and putty contain conductive components which have a unique morphology. The amount of these components to be mixed into the rubber compound to obtain the desired conductivity is relatively small, and therefore the rubber properties of the end product are excellent. The putty, however, has to be very highly filled with conductive components, with the result that its adhesive properties are less than those of the other putties in our production range.

Attenuation tests at DELTA Electronics Testing/Denmark have proved the good attenuation values achieved by the RISE®-EMC system based on CONDUCTON® flexible rubber:

35-85 dB.

A RISE®-EMC penetration based on the conductive tape and sleeves shows a lower value. Damping: **20-60 dB.**

The sealant shows values: **10-30 dB.**

RISE® TYPE EMC PENETRATIONS FOR EMP/EMI PROTECTION



CONDUCTON® is an electrically conductive sealing putty based on a single component silicone compound. CONDUCTON® is also water-repellent. The putty adheres well to metal subsurfaces and is reasonably flexible.

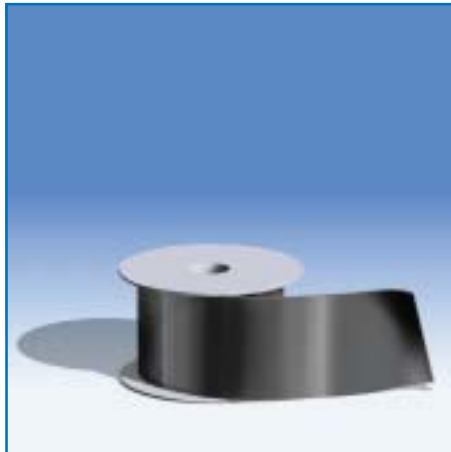

CONDUCTON® tapes are used for wrapping around the cable(s). They are also used to fill up the larger openings inside the CONDUCTON® filler sleeves.



CONDUCTON® filler sleeves are used to fill the remaining spaces in the penetration. They are supplied in 40 mm length. The more compact the filling, the higher attenuation will be obtained.



CONDUCTON® flexible rubber is used to fill the cavity around the ducted cables in the conduit sleeve instead of making use of the putty. This rubber can be modelled by hand and offers the highest attenuation.

PRODUCT INFORMATION

| | |
|-------------------------|---|
| 01) colour | black |
| 02) specific gravity | 1,4 ± 0,03 g/cm ³ |
| 03) tensile strength | 0,8 MPa |
| 04) elongation at break | 40% |
| 05) hardness | 30 Shore A |
| 06) elasticity | approx. 25% |
| 07) good adhesion to | steel, zinc, copper, aluminium |
| 08) resistance | < 100 W |
| 09) supplied in | cartridges containing 310 ml |
| 10) storage | to be stored cool and dry min/max temperature = 5-30 °C |
| 11) storage life | approx. 6 months |

||| CONDUCTON |||

IMPORTANT INFORMATION:

The level of attenuation obtained with a CONDUCTON® penetration is partly dependent on:

- the distance between the ducted cable and the penetration wall
- the contact surface with the conductive materials
- the greater or lesser homogeneous filling of the conductive mass
- the condition of the contact surface in the conduit pipe

ASSEMBLY INSTRUCTIONS RISE®-EMC MULTI-CABLE PENETRATIONS

horizontal



1) The spot where the CONDUCTON® sleeves will be applied must be thoroughly blanked and cleaned to obtain optimum surface contact. The cables can be ducted in random order. Don't pull too tight.



2) After the cables have been ducted, remove the sheathing of the cables over a length of approximately 40 mm (1.6") and wrap the braiding of the cable with CONDUCTON® tape.

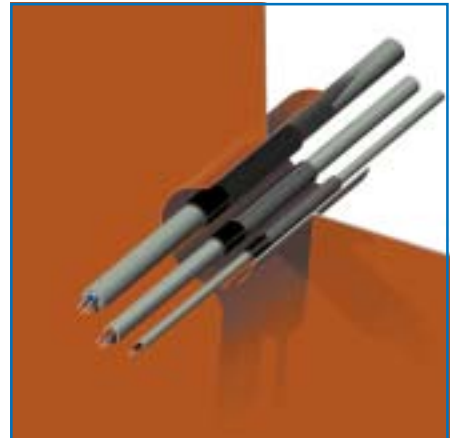

3) Pull the cables back into the conduit sleeve/frame in such a way that the front of the wrapped braiding is about 20 mm (.8") deep inside the conduit sleeve/frame. Place RISE® insert sleeves around the cables.



4) The remaining free space in the conduit is filled with RISE® filler sleeves type 27/19 and 18/12. Push the insert/filler sleeves into the conduit opening in such a way as to leave about 20 mm (.8") free space at the back.



5) Insert sleeves with CONDUCTON® circular profiles are applied to mark the position of insert sleeves to be used for later extensions of the cable set.

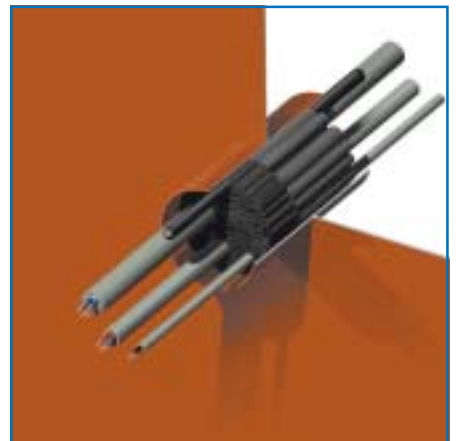

6) The free space around the wrapped cables is filled with CONDUCTON® filler sleeves type 18/12. Push the sleeves compressed into the conduit opening, leaving a 20 mm (.8") free space at the front of the conduit.



7) Remaining openings in the compressed filler sleeves should be filled with pieces of the CONDUCTON® tape to obtain a most compact filling.



8) A 20 mm (.8") thick layer of FIWA® sealant is applied at each side of the conduit. Clean and dry the conduit opening thoroughly and remove any dirt, rust or oil residues before applying the sealant. Apply some overfill.



9) To smooth the surface of the FIWA® sealant layer, a cloth is sprayed with soapy water. This prevents the sealant from sticking to the cloth. For further finishing see the instructions on pages 16-17.

ASSEMBLY INSTRUCTIONS RISE®-EMC MULTI-CABLE PENETRATIONS

vertical



1) The spot where the CONDUCTON® putty will be applied must be thoroughly blanked and cleaned to obtain optimum surface contact. The cables can be ducted in random order. Don't pull too tight.



2) Remove the sheathing of the cables in the conduit sleeve/frame over a length of approximately 40 mm (1.6") in such a way that the front of the exposed braiding is about 20 mm (.8") deep inside the conduit sleeve/frame.

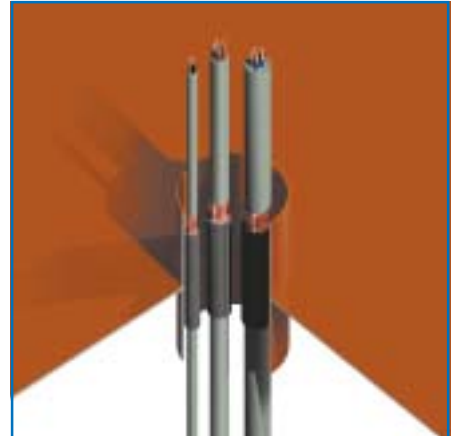

3) RISE® insert sleeves are put around the ducted cables and pushed into the conduit sleeve/frame in such a way that about 60 mm (2.36") free space is left at the front of the conduit and 20 mm (.8") at the back.

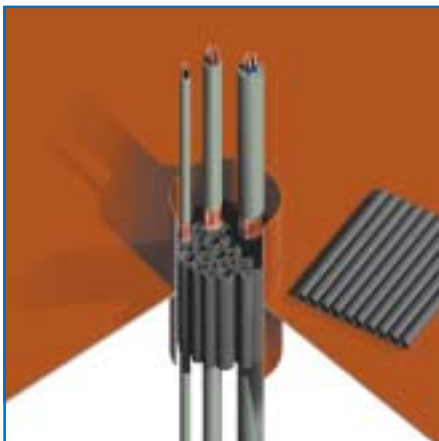

4) The remaining free space in the conduit is filled with RISE® filler sleeves. Push the filler sleeves into the conduit sleeve/frame in the same way as the insert sleeves around the cables.



5) Insert sleeves with electrically conductive CONDUCTON® circular profiles are applied to mark the position of insert sleeves to be used for later extensions of the cable set.



6) After the insert sleeves have been put in place, a 40 mm (1.6") thick layer of electrically conductive CONDUCTON® sealant or flexible rubber is applied against the backing formed by the sleeves.



7) The CONDUCTON® sealing putty has to be carefully applied in between the cables and profiles at the place of the exposed braiding and pressed down firmly to assure good conduction to mass.



8) A 20 mm (.8") thick layer of FIWA® sealant is applied at each side of the conduit. Clean and dry the conduit opening thoroughly and remove any dirt, rust or oil residues before applying the sealant. Apply some overfill.



9) To smooth the surface of the FIWA® sealant layer, a cloth is sprayed with soapy water. This prevents the sealant from sticking to the cloth. For further finishing see the instructions on pages 16-17.

RISE[®]-EMC

MULTI-CABLE PENETRATIONS

DIAGRAMMATIC OVERVIEW OF SHIPBUILDING/ OFFSHORE APPLICATIONS

- L1: A-60 approved bulkhead insulation.
- L2: mineral wool minimum 25 mm, density 110 kg/m³ or equivalent.

**- NO EXTRA INSULATION
REQUIRED AT THE FRONT
OF THE PENETRATION
AND/OR IN BETWEEN THE
CABLES**

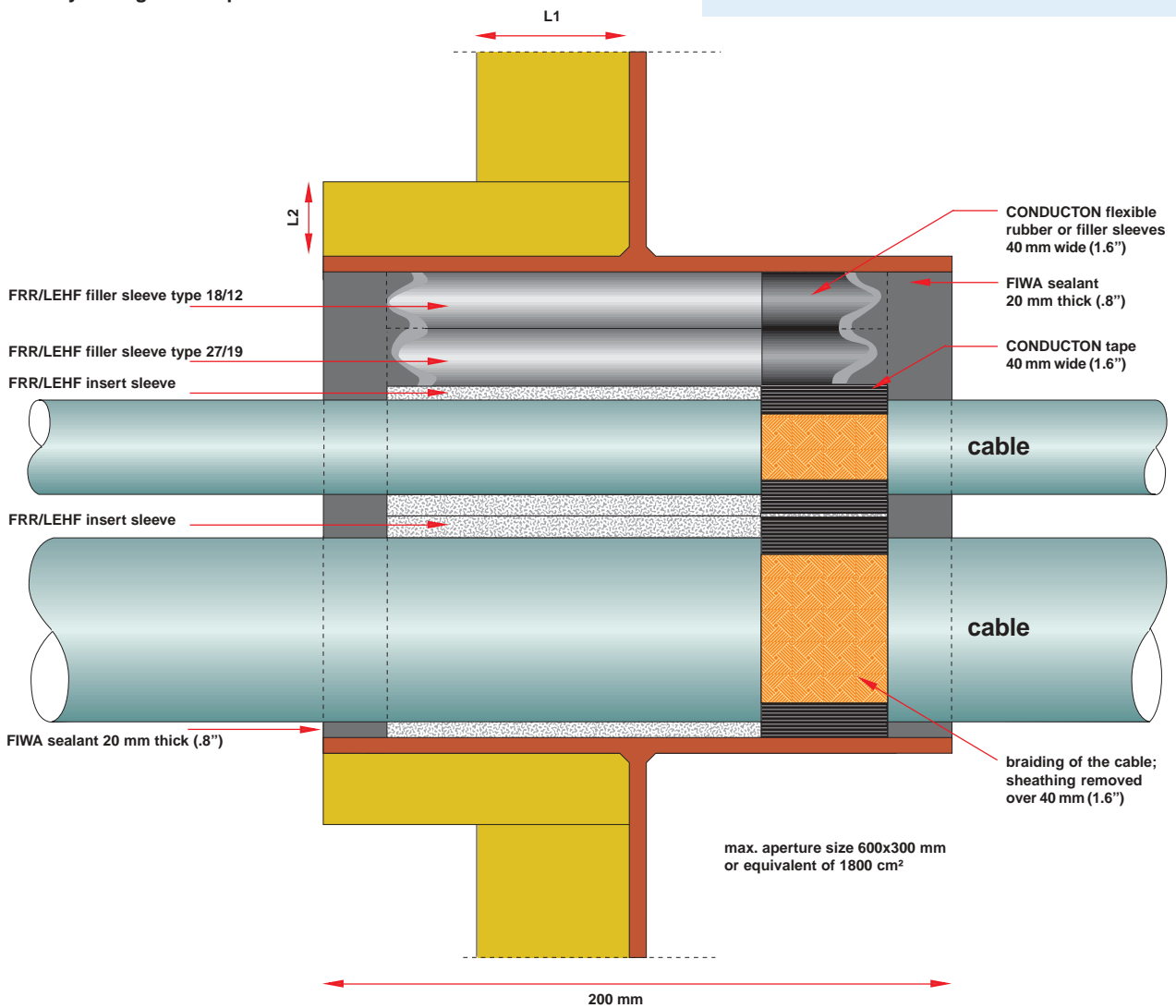

specifications for A-class according to CE certificate
11301/A0 EC issued by Bureau Veritas



**A0-A60
CABLE PENETRATION
BULKHEADS**

RISE[®]-EMC MULTI-CABLE PENETRATIONS

DIAGRAMMATIC OVERVIEW OF SHIPBUILDING/ OFFSHORE APPLICATIONS

- L1: A-60 approved deck insulation.
- L2: mineral wool minimum 25 mm, density 110 kg/m³ or equivalent.

- NO EXTRA INSULATION REQUIRED AT THE FRONT OF THE PENETRATION AND/OR IN BETWEEN THE CABLES

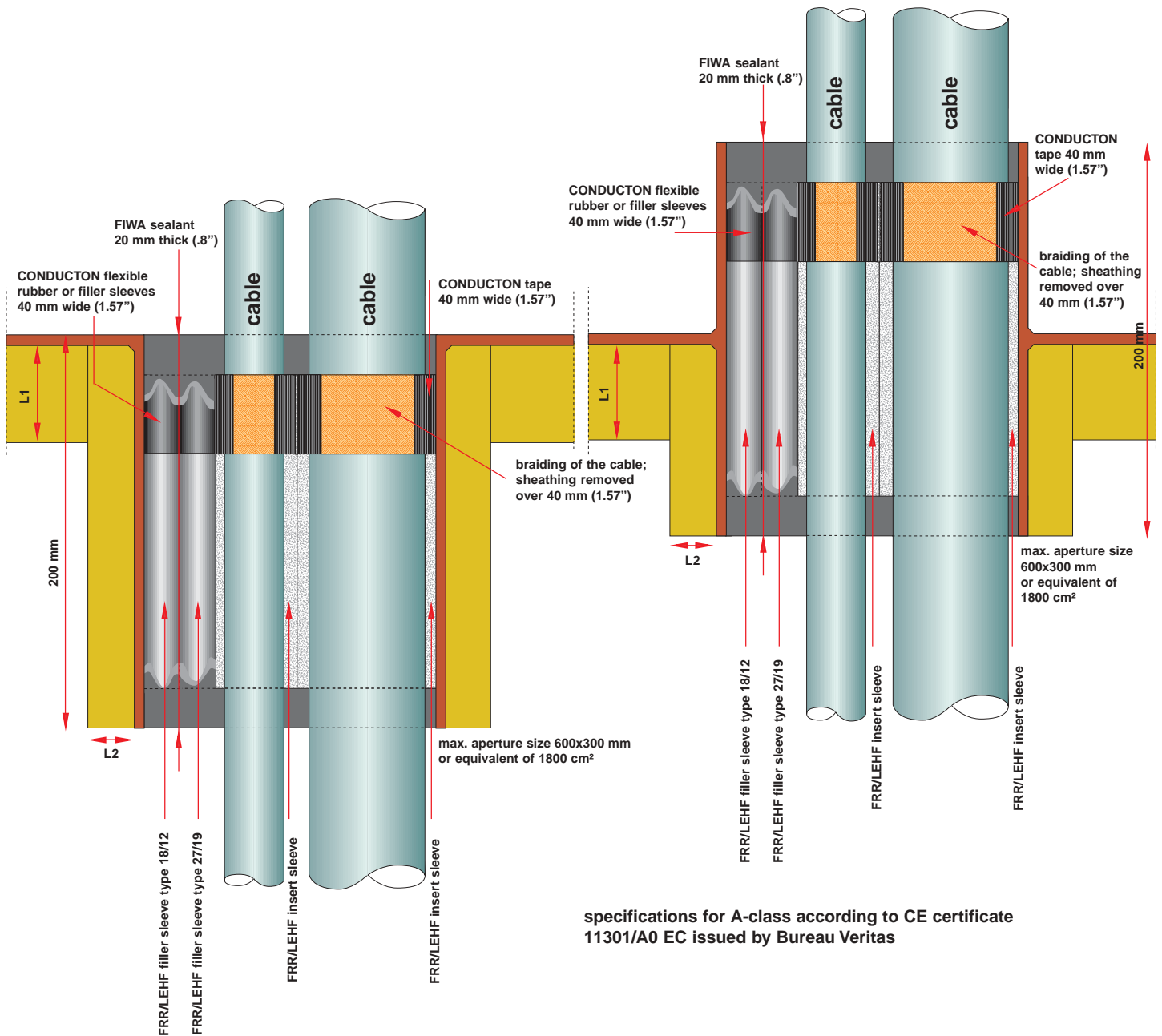

specifications for A-class according to CE certificate 11301/A0 EC issued by Bureau Veritas



**A0-A60
CABLE PENETRATION
DECKS**

RISE[®]-EMC WATERTIGHT MULTI-CABLE PENETRATIONS

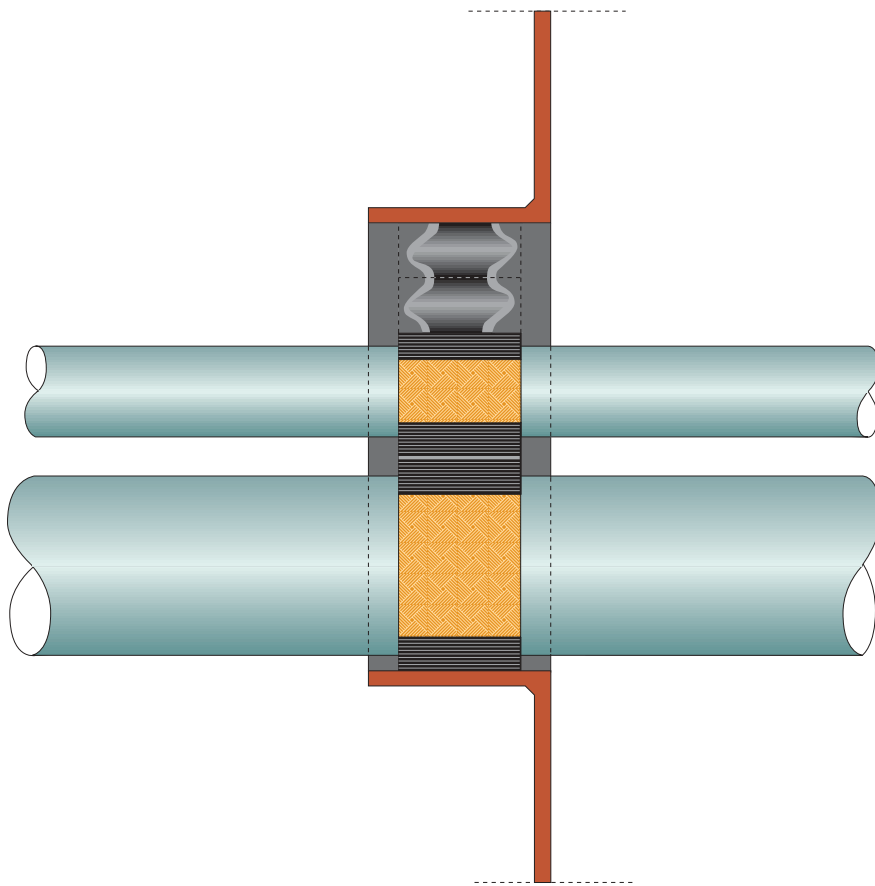

For watertight RISE[®]-EMC penetrations it is not necessary to use RISE[®] insert and filler sleeves. Place 40 mm CONDUCTON[®] tape and filler sleeves or flexible rubber around the cables and then apply a layer of 20 mm FIWA[®] sealant at both sides of the penetration.

Minimum conduit length 80 mm to obtain similar tightness as with the standard RISE[®] system.

For watertight RISE[®]-EMC deck penetrations the procedure is the same. If the required watertightness is not exceeding 0.5 bar the FIWA[®] layers can be reduced to 10 mm so that the conduit length is limited to 60 mm.

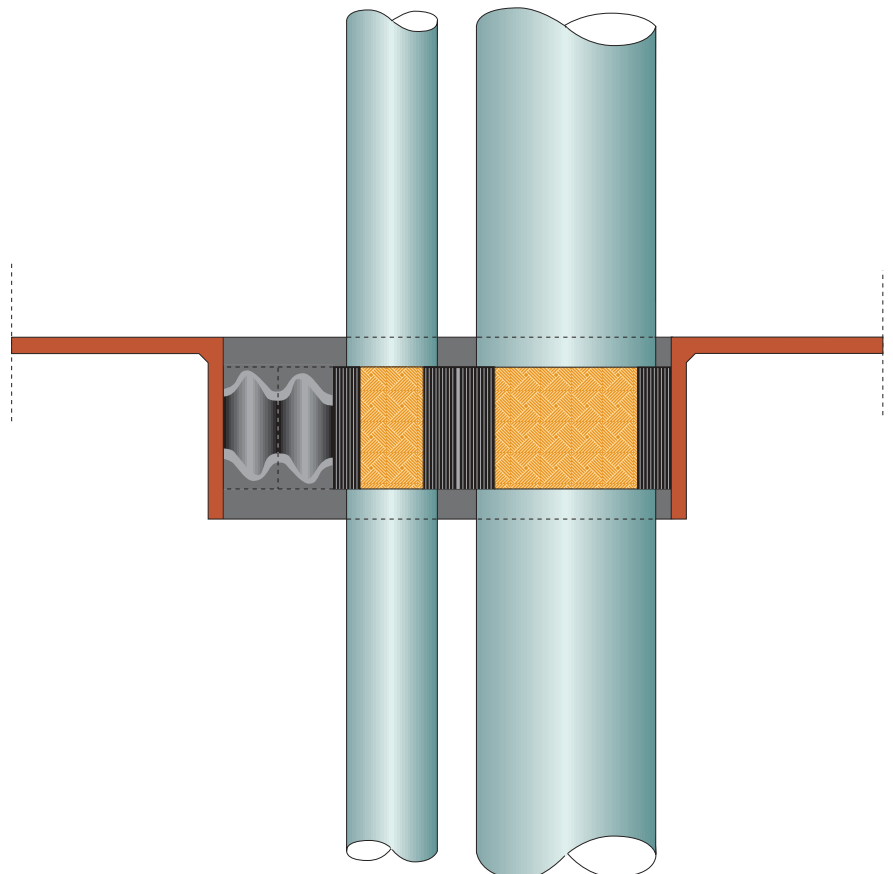

RISE[®] WATERTIGHT MULTI-CABLE PENETRATIONS

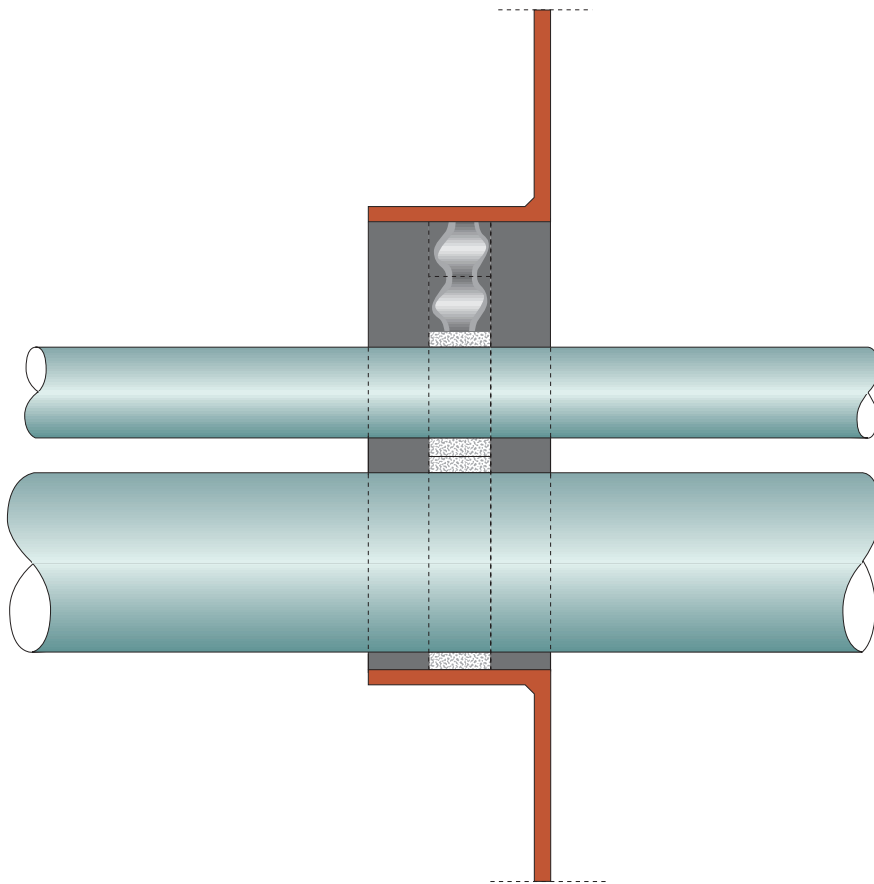

The most simple way to obtain a watertight RISE[®] penetration is to place insert sleeves with a length of 20 mm around the cables and to fill the remaining space in the conduit with 20 mm long filler sleeves. Then apply a layer of 20 mm FIWA[®] sealant at both sides of the penetration. Conduit length 60 mm. Tightness 2.5 bar. LRS certificate APE 0109113/1

In case the conduit has limited dimensions, a watertight RISE[®] penetration can be obtained by filling the whole conduit opening with FIWA[®] sealant. Maximum conduit length 60 mm. The curing time of the 60 mm FIWA[®] will be several weeks because the air humidity cannot easily penetrate to the inside.

Tightness 2 bar.
LRS certificate
APE 0009060/2

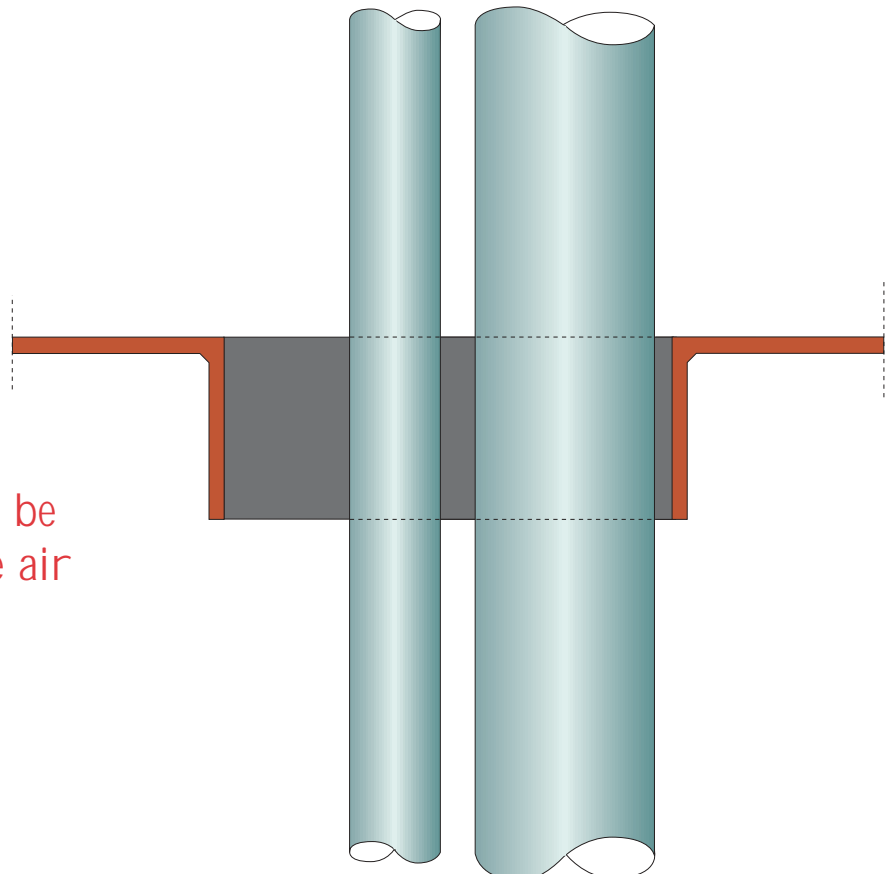

RISWAT® SEALING SYSTEM FOR WATERTIGHT CABLE ENTRIES

The RISWAT® system was specially developed for gas and water tight penetrations in which the cable(s) or pipe(s) are exposed to continuous vibrations. In such cases there is a need for a highly flexible sealant with a reduced hardness of about 20° Shore A. For this purpose the DRIFIL® sealant has been developed. For RISWAT® penetrations, the entire space around the cables/pipes in the conduit is filled up with THERFIL inserts about 100 mm (4 inches) long. These are made from a specially developed extrudable rubber. A layer of DRIFIL® sealant about 20 mm (.8 inches) thick is then applied on the resultant carrier. Temperature range -40° C to +120° C.

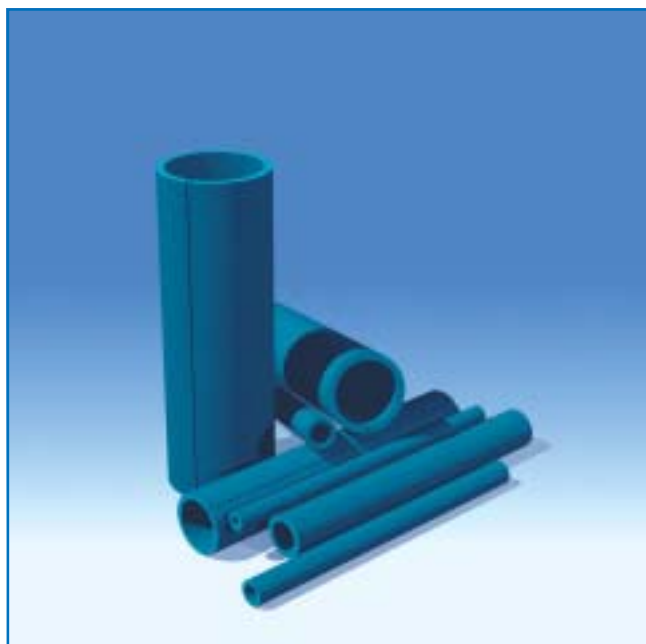
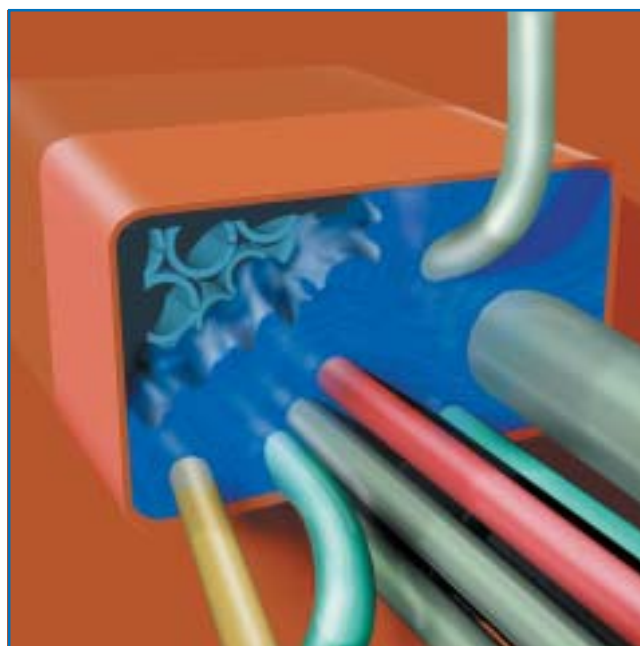

THERFIL sleeves are made from a specially developed extrudable rubber. THERFIL sleeves have a clearly recognizable blue colour to ensure that they are easily distinguishable from the RISE® sleeves which are used for fire-resistant conduits. THERFIL sleeves have a standard length of 500 mm (19.70 inches), and can be cut to length as required on the construction site.

RISWAT



| sleeve type | cable diameter | sleeve length | sleeve type | cable diameter | sleeve length |
|-------------|----------------|---------------|-------------|----------------|---------------|
| 12/6 | 5 - 7 | 500 | 20/14 | 13 - 15 | 500 |
| 14/8 | 7 - 9 | 500 | 22/16 | 15 - 17 | 500 |
| 16/10 | 9 - 11 | 500 | 27/19 | 17 - 21 | 500 |
| 18/12 | 11 - 13 | 500 | 31/23 | 21 - 25 | 500 |

dimensions in mm

DRIFIL® is a water-repellent sealant based on a single-component silicone material. In developing DRIFIL® sealant, high priority was focused on its power of adhesion to subsurfaces such as steel, stainless steel and aluminium, and to plastic cable sheathings. In addition, special attention was given to the permanent flexibility of the sealant in order to permit movements of the penetration after the sealant has set. The purpose of this is to ensure that the seal remains intact in the longer term even in spite of possible mechanical loading. DRIFIL® sealant has a very short setting time. The top layer is rapidly tack-free. In contrast to the RISE® system, the water and gas tightness of the RISWAT® system is limited due to the softer sealant layer.

Approved for 1.5 bar, LRS certificate APE 0009060/1.

HIGH-TECH SEALANTS FOR SPECIFIC SOLUTIONS

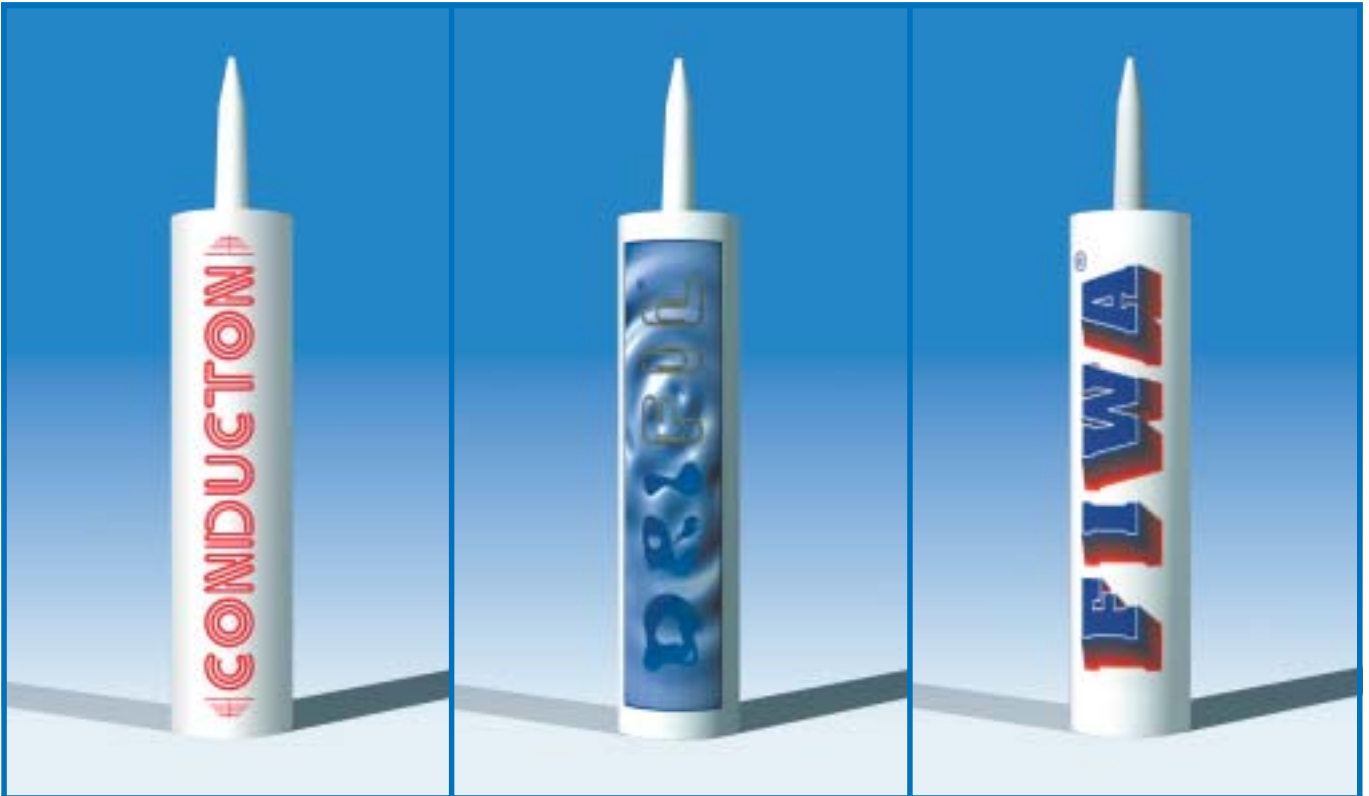

CONDUCTON® is an electrically conductive putty based on a single component silicone compound. CONDUCTON® is also water-repellent. The putty adheres well to metal subsurfaces and is reasonably elastic. CONDUCTON® contains components with a unique morphology to obtain the necessary high grade of conductivity. CONDUCTON® has a measured resistance of 50-60 Ohm. Optimum contact with the cable or structure to be shielded is essential for effective EMC protection. Measurements have shown that the attenuation is in the range of 10 - 20 dB, when applied with a surface contact of 40-50 mm for pipe and cable penetrations. CONDUCTON® is used for the RISE®/EMC and the CSD®/EMC systems.

DRIFIL® is a water-repellent sealing compound based on a single-compound silicone material. In developing DRIFIL® sealing compound, high priority was focused on its power of adhesion to subsurfaces as occurring in the construction sector, and to cable sheathing and metal and plastic pipes. In addition, special attention was given to the permanent flexibility of the sealing compound in order to permit minor settlements and movements of the cable/pipe bunch after the compound has set. The purpose of this is to ensure that the seal remains intact in the longer term even in spite of possible mechanical loading. DRIFIL® sealing compound has a very short setting time. The top layer is rapidly tack-free.

FIWA® is a fire-resistant sealing putty based on a single component silicone compound. FIWA® is also water-repellent. The putty adheres well to most subsurfaces occurring in the building industry, and is permanently elastic. In the event of fire or at temperatures in excess of 200 °C the putty expands to about ten times its original volume. During this process a porous mass is formed which has excellent thermal insulation properties. In contrast to conventional materials that swell under severe heat exposure, the expansion of FIWA® is not caused by intumescence, but by a chemical process. The advantage of this is that the expansion of FIWA® is not accompanied by the formation of fumes.



For ease of application of very high viscosity sealants, we have selected a powerful manual applicator with a 26 : 1 trigger leverage. This means much easier dispensing and reduced fatigue. The applicator is equipped with the so-called Wear Compensating Device, which automatically removes free-play in the trigger to provide instant rod drive immediately when the trigger is pulled. Less full trigger strokes required to empty a cartridge. Extended working life of the applicator. Ergonomically contoured handle and trigger for comfortable operation with less hand fatigue.



We have also selected a powerful pneumatic applicator for highest productivity. Quiet operation (less than 70 dB). Air supply to suit most standard systems. Fast, easy pressure regulation for accurate flow control. High volume trigger valve for immediate sealant flow. Ergonomic design: comfort, minimal operator fatigue. Short, well balanced design, combined with lightweight engineering plastic and aluminium components. Also available for 1 liter cartridges.

RISE[®]

CABLE AND PIPE PENETRATIONS

*ease of calculation with
RISE[®] cable and pipe penetrations*



Can be downloaded from our website <http://www.beele.com>.

Call us for a free CD and/or your registration number!

Feature for automatic update via our website every time the program is started.

After the entry of the dimensions of the conduit opening and the amount and outer diameters of the ducted cables or pipes, the software calculates the amount of RISE[®] sleeves and FIWA[®] sealant.

A drawing appears on the screen showing also the remaining free space in the conduit opening.

All calculated transits can be stored in a database.

Prints order/calculation forms.

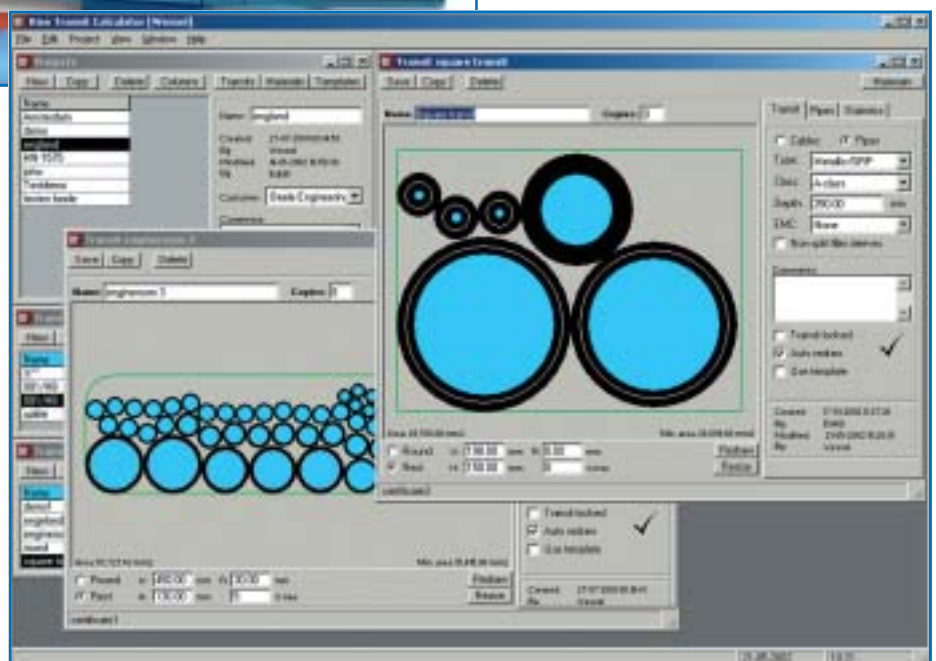

*we are there with full support for
RISE[®] cable and pipe penetrations*

RISE[®] CABLE AND PIPE PENETRATIONS

*well documented information comes with
RISE[®] cable and pipe penetrations*

*free promotional video of the
RISE[®] cable and pipe
penetrations available*

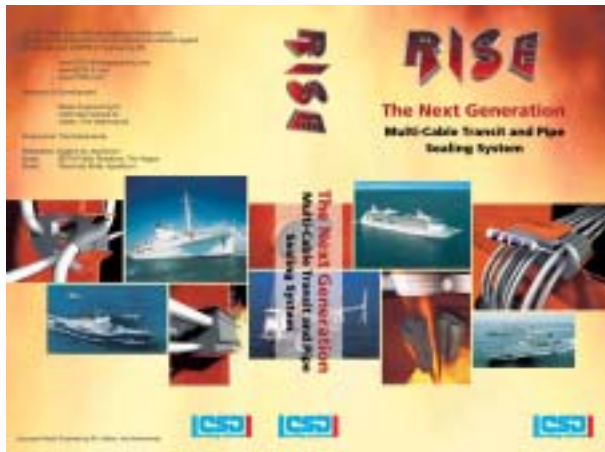

It's not merely a system to sell. Our Research & Development Department has put a lot of effort into the system, not only with regard to ease of installation, material handling on site, maintenance and outstanding performance under the most severe conditions, but also in the availability of certificates, installation instructions, brochures, *a free promotional video and a free CD with the "RISE[®] transit calculator" software.* Ask for it!

*free instruction video of the
installation of RISE[®] cable and
pipe penetrations available*



The Trimaran craft is regarded as the naval vessel of the 21st century. On board this advanced naval vessel RV Triton we were allowed to make a video of the installation of the RISE[®] sealing system for both pipe and cable penetrations and of the CSD[®] sealing plugs for pipe penetrations. The video shows clearly the ease of installation both for bulkhead and deck penetrations. The engineers of our Research & Development Department demonstrate how it's done. Ask for it!

*free video of the installation of
a RISE[®] multi-cable penetration
witnessed by a notary and a
surveyor available*



Many customers have made their own time studies to determine the cost savings before deciding to switch to the RISE system. These savings are substantial. Sometimes we face the fact that there are some nonbelievers about this issue. For this reason we decided to take an unusual step. Witnessed by a notary public and a classification society an installation was performed to deliver proof that our claims of speed and ease of installation are true. Ask for the video!

*we are there with full support for
RISE[®] cable and pipe penetrations*

RISE[®]

CABLE AND PIPE PENETRATIONS

PROVEN ADVANTAGES IN NEW CONSTRUCTIONS AND FOR REFURBISHMENTS OR IMPROVEMENTS OF EXISTING INSTALLATIONS, IN A- AND H-CLASS DIVISIONS, FOR PIPE AND CABLE PENETRATIONS

RISE

RISE[®] has been used on numerous drillships, FPSO's and offshore constructions



Built by Derecktor Shipyards, New York. Currently the fastest passenger ferry in the USA. CSD sealing plugs type FRR used for all pipe penetrations through fire rated bulkheads and decks. RISE Multi-Cable Transit System used for all cable penetrations through fire-rated/watertight bulkheads and decks.

RISE[®]

CABLE AND PIPE PENETRATIONS

RISE[®] has been used for all cable penetrations on a series of shuttle tankers built by Samsung Heavy Industries, Korea. Meanwhile the RISE[®] system is the standard sealing system for all further constructions at the yard.



time saving
space saving
weight saving
cost effective



1) M/S "DOULOS" has been totally refurbished and is used today for educational programs of the United Nations. During the refurbishment all penetrations on board of the vessel were sealed with the RISE[®] system.

2) RISE[®] has been applied for cable penetrations on several FPSO's like the Schiehallion built at Harland & Wolff, Belfast, and several FPSO's built in Singapore.

3) Trimaran Prototype built by Vosper Thornycroft. All cable penetrations are sealed with the RISE[®] multi-cable sealing system and all pipe penetrations with CSD[®] sealing plugs.

Revolutionary sealing systems used on the RV Triton

The Trimaran craft is regarded as the naval vessel of the 21st century. On board this advanced naval vessel RV Triton, the RISE® system and CSD® Sealing Plugs are used extensively for sealing cable and pipe penetrations.



RISE® for multi-cable penetrations

The RISE multi-cable system is used for sealing all the cable penetrations on board of the RV Triton. RISE was chosen for the following reasons:

- **Improved Safety** - RISE has been tested in accordance with the IMO A.754(18) standard and is approved for use in A60 class boundaries. RISE expands 5-10 times when exposed to fire, creating the best possible barrier, preventing the passage of flames, gases, smoke and water even if the deck is collapsing.
- **Space and weight saving** - RISE is the most compact system on the market, saving space and weight. The RISE system does not require the use of special transit frames, almost any size or shape pipe or conduit can be utilised, giving more flexibility in designing the size and position of transits.
- **Reduced design time** - A specially developed RISE software program enables customers to design a RISE transit in a few minutes calculating the size, shape, free space and material required.
- **Ease and flexibility of installation** - The RISE system is quick to install. It consists of just two components: rubber insert sleeves or sheets and a silicone-based fire resistant and water repellent sealant. Expanding Halogen Free Rubber insert sleeves are placed around each cable, the remaining spare space is filled with extra sleeves, leaving about 20 mm space at either end of the penetration. A layer of FIWA putty is then applied on both sides.
- **Extremely easy to remove or add a new cable** - This is important as it is envisaged that the cabling will be changed throughout the life of RV Triton. Re-entering the RISE system for later extension is a simple and fast procedure.
- **Certification** - RISE has been successfully tested to the ISO and Naval Engineering standards for shock and vibration, toxicity, oxygen and smoke index, ageing process and surface flame propagation. *The system is fully certified for use in A-60 fire divisions and water and gas tight bulkheads and decks by all major classification societies. CE certified.*

RISE® for pipe penetrations



RISE has also been used for pipe penetrations where the pipe is off centre or passing through the penetration at an angle and for all multiple-pipe penetrations.

This system provides all the same benefits as the plugs.

CSD® Plugs for pipe penetrations

CSD Sealing Plugs have been used extensively on board the RV Triton for pipe penetrations through watertight and Fire Rated Bulkheads and Decks. The sealing plugs are made from fire safe FRR rubber and provide many benefits over the traditional methods of passing pipes through bulkheads and decks:

- **Weight saving** - Combined with pipe couplings the system has helped to reduce weight significantly as it eliminates the need for bulkhead pieces and flange sets.
- **Reduce corrosion** - The system provides cathodic protection between dissimilar metals as the service pipe is isolated from the bulkhead. This eliminates the problems of welding.
- **Improved design and production times** - The pipe sleeve can be designed and installed prior to knowing the exact service pipe dimensions allowing them to be installed at the plating stage. This is made possible because one sleeve can accommodate a wide size range of service pipes and the size of CSD plug is simply chosen to fit the service pipe.
- **Reduced labour costs** - The plugs can be installed in minutes.
- **No bulkhead pieces are required** - The plugs allow the service pipe to be passed straight through the bulkhead without the need for a joint, there is no Hot Dip Galvanising required.
- **Vibration and sound damping** - The plugs are made of rubber therefore providing significant vibration and sound damping.
- **Certification** - CSD Sealing Plugs are approved by all the major classification societies including the new EC Marine Directive, for use in A60, water and gas tight bulkheads and decks for all pipe penetrations including GRE and plastic pipes.

Conclusion

RISE and CSD Plugs can enable users to realise substantial cost savings throughout their entire project and reduce lifetime costs for the owner.

"We used the RISE system for all our cable penetrations on board the RV Triton and found it extremely versatile, we will certainly look to use the RISE system on future projects."

Steve Nicholson, Electrical Manager, RV Triton, Vosper Thornycroft



A copy of the video showing the actual installation on board the RV Triton is available direct from BEELE Engineering bv:
Tel:+31 (0)543 461673, Fax:+31 (0)543 461786 E-mail: info@beele.com Websites: www.beele.com and www.rise-systems.com

FIRE SAFE SEALING SYSTEMS FOR CABLE AND PIPE PENETRATIONS

May we remind you of a number of recent fires? For example, there were the tragic losses of the Scandinavian Star ferry and the Piper Alpha rig. Each of these fires caused more than 160 fatalities. Although the fire on board of the Achillo Lauro resulted in no casualties, it did lead to the sinking of the vessel. In addition, there have been fateful fires on navy vessels, like the Sheffield in the Falklands, the Stark in the Gulf, and the Walrus while still under construction, all of which have gone to prove how vulnerable ships can be in the event of fire.



All the more reason, you will surely agree, to give particular consideration not only to the installation of smoke detectors, sprinkler systems, fire-fighting equipment, etc. but also to the products and systems for passive fire prevention which have been specially developed by BEELE Engineering.

FIRESAFE SEALING SYSTEMS FOR PIPE AND CABLE PENETRATIONS

FIRESAFE
GAS- AND WATERTIGHT
VIBRATION PROOF
SOUND DAMPING
MAINTENANCE FRIENDLY
CERTIFIED
IN OTHER WORDS:
OPTIMIZED SAFETY ON BOARD



LIMIT THE
RISK OF
FLAME AND
SMOKE
SPREAD

PIPE APPLICATIONS

CSD® SEALING PLUGS FOR PIPE CONDUITS

CSD® sealing plugs for individually ducted pipes consist of two equal parts so that they can be installed after the pipes have been laid. The unique profile both inside and outside the sealing plug guarantees a very high level of gas and water tightness. The serrated profile on the outside is designed to allow the plug halves to

be snugly fitted in the conduit sleeves. The sealing plugs are gas and water tight up to excess pressures of 2 bar on the flanged side and up to 1 bar at the other side of the plug. CSD® sealing plugs are supplied in six different rubber grades to cater for a wide variety of applications. **Certified for A- and H-class conduits.**



**MOST EASY TO INSTALL -
FIRESAFE - WATER TIGHT -
GAS TIGHT - DUST TIGHT -
VIBRATION PROOF - SOUND
DAMPING - NO CORROSION**

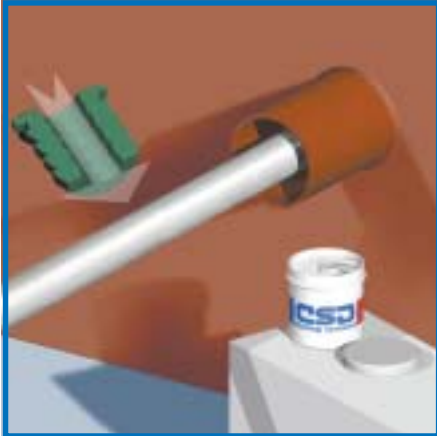

The inside wall of the conduit sleeve and the segments of the sealing plug are treated with CSD® lubricant.



Both segments of the CSD® sealing plug are pushed evenly, serration by serration, into the conduit opening.

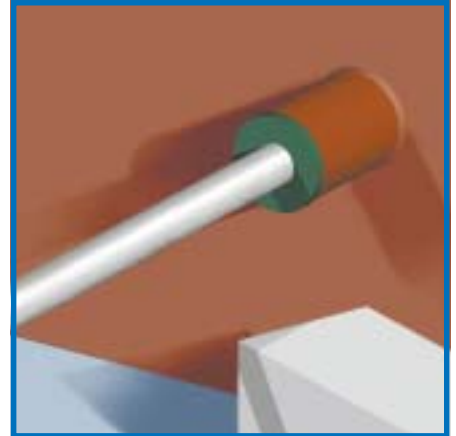

The flanged edge of the sealing plug must be flush against the front side of the conduit sleeve.

RISE® AND RISWAT® SEALING SYSTEM FOR ECCENTRIC AND HIGHLY FLEXIBLE CONDUITS

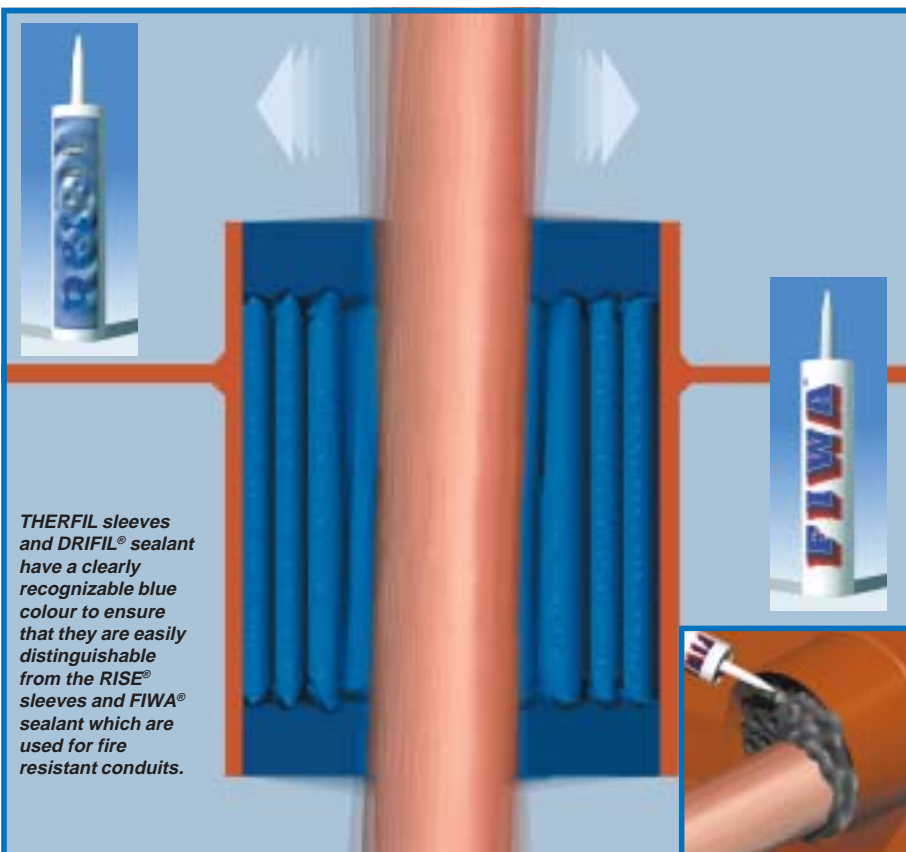

THERFIL sleeves and DRIFIL® sealant have a clearly recognizable blue colour to ensure that they are easily distinguishable from the RISE® sleeves and FIWA® sealant which are used for fire resistant conduits.

The RISE® system can be used for eccentrically positioned firesafe pipe penetrations. CSD® sealing plugs can generally not be applied in such cases because the pipe has to be in the centre of the conduit opening. Use is made of rubber strips made of expandable FRR/EHF rubber (placed around the pipes) and RISE® filler sleeves. On both sides of the penetration a layer of FIWA® sealant (fire resistant, water repellent) is applied.

Colour: anthracite

The RISWAT® system was specially developed for gas and water tight pipe penetrations in which the pipe(s) are allowed to move in all directions. The entire space around the pipe in the conduit is filled up with THERFIL insert sleeves. The shorter the length of the sleeves, the more movement of the ducted pipe is allowed. A layer of DRIFIL® sealant is then applied on the resultant carrier.

Colour: blue

CABLE APPLICATIONS

RISE® MULTI-CABLE PENETRATIONS

RISE® multi-cable penetrations are an alternative for the casting compounds and block systems in fire-rated decks and bulkheads. Very easy to install. The very limited amount of different parts makes this system easy to handle on site. Use is made of rubber inserts (placed around the cables) and filler sleeves.

On both sides of the penetration a layer of FIWA® sealant (fire resistant, water repellent) is applied.

No pre-engineering of the conduit is needed. In contrast to many other sealing systems, RISE® multi-cable penetrations do not require the use of special conduit frames.

Certified for A- and H-class conduits.



- FIRESAFE - WATER TIGHT
- EASY TO INSTALL
- NO PRE-ENGINEERING
- NO SPECIAL CONDUIT FRAMES
- VERY COMPACT ASSEMBLY

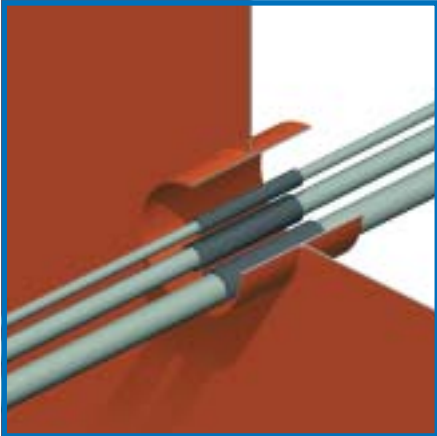

After all the cables have been ducted, a RISE® insert sleeve is applied around each cable.

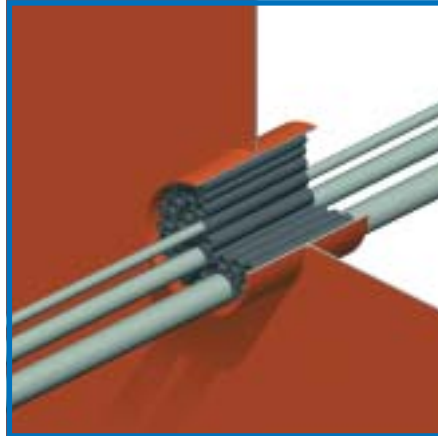

The remaining free space in the conduit is filled with RISE® empty sleeves. Fill the space on top with FIWA® sealant.



With a damp cloth the FIWA® sealant is forced into and between the empty sleeves to ensure a homogeneous filling.

THE COMPONENTS OF A RISE® CABLE PENETRATION



For the RISE® insert sleeves and the FIWA® sealant special compounds were developed. When these compounds are exposed to fire or temperatures in excess of 200 °C they expand to 5-10 times their original volume.



- LIMITED NUMBER OF COMPONENT
- NO SPECIAL TOOLS
- NO BOLTS AND NUTS
- NO SPECIAL CONDUIT FRAMES



a) An extremely limited number of different components are used for the sealing of the conduit. Only fifteen different sizes of insert sleeves are used, for cables from 5 mm to 63 mm. For larger diameters, rubber strips cut from rubber sheets are applied.

b) The only tools and accessories needed to finish the conduit are a compound gun, a flower spray, a trowel, a cloth and a small spatula.

c) The sealing is finished by applying a layer of FIWA® sealant at each side of the conduit.

CABLE/PIPE APPLICATIONS

BEESEAL® MULTI-PIPE/CABLE PENETRATIONS

The BEESEAL® multi-sealing module system (MSM) is used particularly in cases where large numbers of pipes/cables have to be ducted as compactly as possible.

The modules are supplied in a wide range of types, so that it is a simple matter to adjust the modular system to the pipe/cable configuration.

The serrated profile on the outside is designed to allow the modules to be snugly fitted in the conduit frames. The MCP conduit frames are available in numerous configurations.

The BEESEAL® transit system is gas and water tight up to excess pressures of 1 bar.

Certified for A- and H-class conduits.



**MOST EASY TO INSTALL -
FIRESAFE - WATER TIGHT -
GAS TIGHT - ABSORBING THE
VIBRATIONS OF HYDRAULIC LINES
- VERY COMPACT ASSEMBLY**



The inside wall of the conduit frame and the outer surfaces of the BEESEAL® sealing modules are treated with CSD® lubricant.



All the modules are pushed into the frame as far as the first serration and then tapped in evenly until the flange edges are flush with the front of the frame.

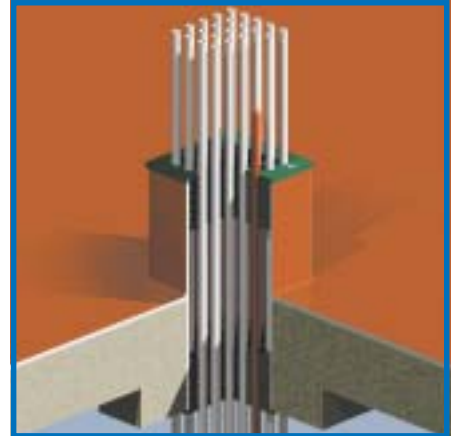

The conduit frame must be insulated with the same insulation in the same thickness as used to insulate the bulkhead or deck.

CSD® MULTI-SEALING PLUGS FOR A WIDE VARIETY OF APPLICATIONS

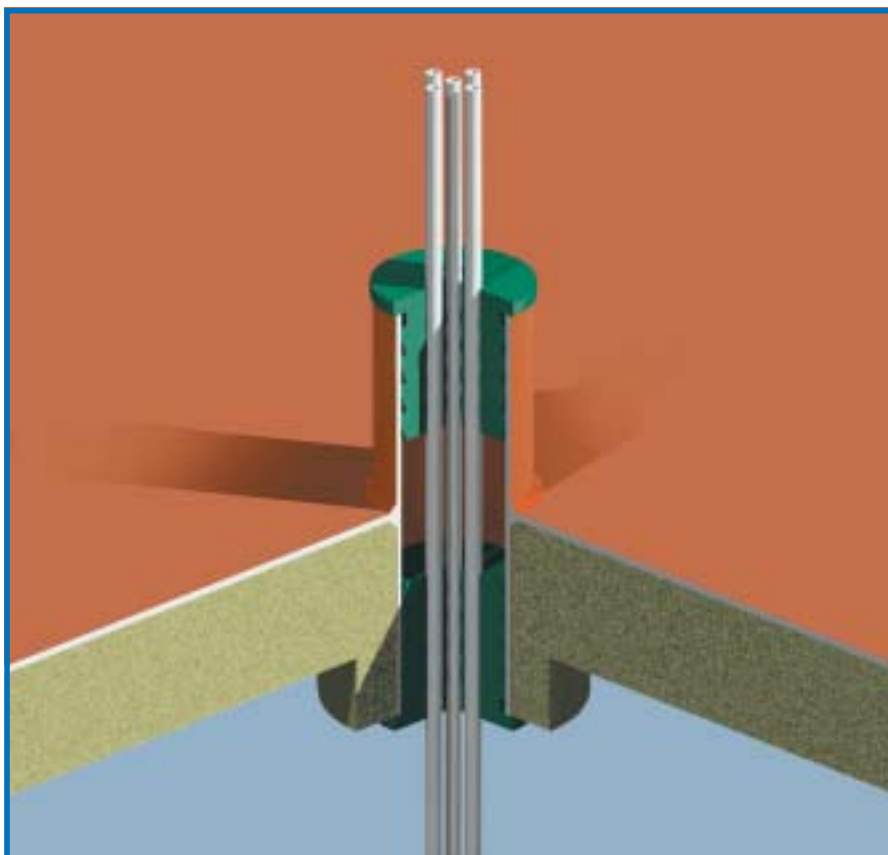

CSD® multi-sealing plugs consist of two, three or four equal parts, so that they can be installed after the cables or pipes have been laid. The unique profile both inside and outside the sealing plug guarantees a very high level of gas and water tightness.

CSD® multi-sealing plugs are used for two, three or five **same diameter cables or pipes** ducted through the same transit opening.



PLASTIC PIPE APPLICATIONS

FIRESAFE PLASTIC PIPE PENETRATIONS

Plastic pipes which pass through fire-rated bulkheads and decks as part of, for example, sanitation systems, are a potential source of serious problems in case of fire. PVC/ABS/PE/PP pipes start to soften at a temperature of about 75 °C and ignite at a temperature of about 140 °C.

This means that, should a fire occur, a hole will be formed by the softened or combusted plastic pipe, allowing fumes and flames to spread freely. In order to meet this problem, use can be made of the RISE® sealing system.

For larger plastic pipes the CSD® crusher plugs can be used for firesafe penetrations of PVC, ABS, PP and HDPE pipes.

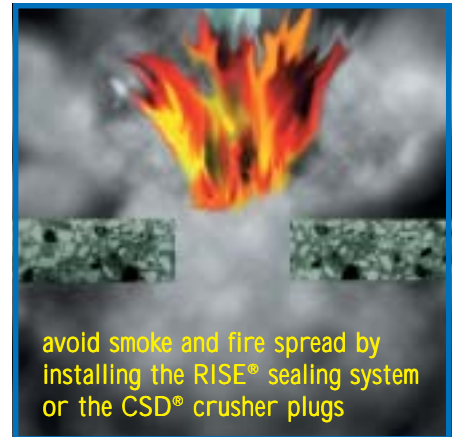
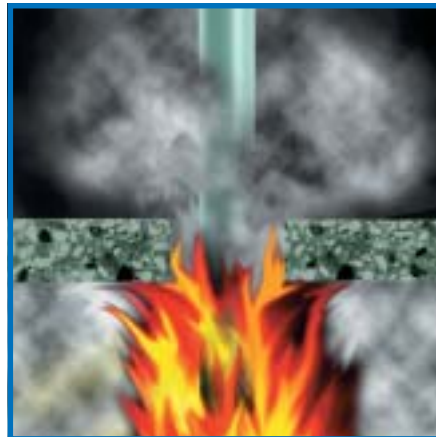
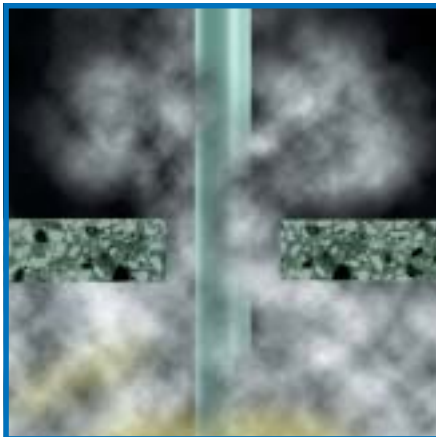

Immediately after a fire breaks out, fumes will be able to spread to adjacent areas through unsealed conduit openings.

As soon as the plastic pipe ignites, the fire will be able to spread and grow virtually unhampered so that ultimately

the pipe disappears altogether at that site, thereby creating an even larger opening through which fumes and flames can pass at will.

THERE ARE JUST TWO SOLUTIONS TO THIS PROBLEM

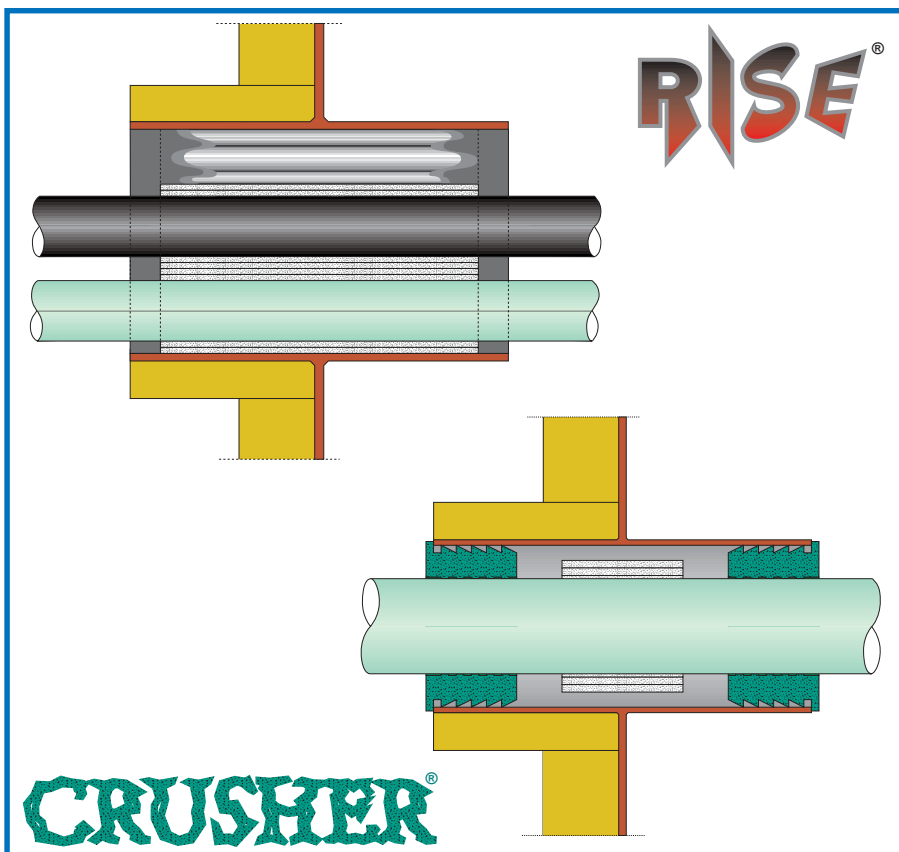

RISE® single and multi-plastic pipe penetrations can be used for plastic pipes up to 75 mm. For plastic pipes larger than 75 mm up to 125/160 mm the CSD® crusher plugs, above 160 mm RISE® crusher collars are to be used.

Official fire tests, both on a full scale deck and bulkhead, according to IMO Resolution A.754(18) have successfully been carried out at the Warrington Fire Research Institute in England. **CE certificate Bureau Veritas Nr. 10710/A1 EC.**

For the same purpose CSD® crusher plugs have been developed for firesafe deck and bulkhead penetrations of plastic and composite plastic pipes. For this purpose a totally new rubber compound (type FRR-E = fire resistant rubber - expanding) has been developed. **CE certificate Bureau Veritas Nr. 09155/A8 EC.**



**MAXIMUM SIMPLICITY OF USE
OPTIMUM FLEXIBILITY
OUTSTANDING PERFORMANCE**

Websites: <http://www.beele.com>, www.rise-systems.com and www.yfestos.com

**ASK FOR THE SEPARATE BROCHURES
ON OUR PRODUCT RANGES:**

- * RISE® MULTI-CABLE TRANSIT SYSTEM
- * RISWAT® WATERTIGHT, FLEXIBLE PIPE AND CABLE TRANSITS
- * BEESEAL® MULTI-PIPE AND CABLE PENETRATIONS
- * CSD® SEALING PLUGS FOR METALLIC AND PLASTIC PIPE ENTRIES
- * CSD®-SQ MULTI-CABLE TRANSITS
- * LEAXEAL® GRIP SEALS
- * YFESTOS® AFTERGLOW ESCAPE ROUTE MARKING



CONDUIT SEALING DEVICES OF AN
AMAZING SIMPLICITY WITH AN
OUTSTANDING PERFORMANCE



BEELE Engineering and CSD International have been involved with fire, water and gas tight sealing for 30 years. We have developed and tested products proven to provide the utmost in sealing protection around the world. To receive our complete civil construction and/or marine products catalogues, please contact your distributor or local representative.

distributed by:

BEELE Engineering bv - CSD International bv
Beunkdijk 11

7122 NZ AALTEN - THE NETHERLANDS

Tel. +31 543 461673 - Fax +31 543 461786 - E-mail: info@beele.com

Websites: <http://www.rise-systems.com> and www.beele.com